



Instructions manual

Series DP

Target disk flowmeter



HART COMMUNICATION FOUNDATION



The art of measuring

PREFACE

Thank you for choosing a product from Tecfluid S.A.

This instruction manual allows the installation, configuration, programming and maintenance. It is recommended to read it before using the equipment.

WARNINGS

- This document shall not be copied or disclosed in whole or in any part by any means, without the written permission of Tecfluid S.A.
- Tecfluid S.A. reserve the right to make changes as deemed necessary at any time and without notice, in order to improve the quality and safety, with no obligation to update this manual.
- Make sure this manual goes to the end user.
- Keep this manual in a place where you can find it when you need it.
- In case of loss, ask for a new manual or download it directly from our website www.tecfluid.com Downloads section.
- Any deviation from the procedures described in this instruction manual, may cause user safety risks, damage of the unit or cause errors in the equipment performance.
- Do not modify the equipment without permission. Tecfluid S.A. are not responsible for any problems caused by a change not allowed. If you need to modify the equipment for any reason, please contact us in advance.

TABLE OF CONTENTS

SERIES DP

1	INTRODUCTION	6
2	WORKING PRINCIPLE	6
3	RECEPTION	6
4	INSTALLATION	7
4.1	Straight pipe sections	7
4.2	Gaskets	7
4.3	Internal diameter	7
4.4	Flow direction	8

LIMIT SWITCH AMD

5	INTRODUCTION	9
6	OPERATION	9
7	MOUNTING THE LIMIT SWITCH IN AN EXISTING EQUIPMENT	10
7.1	Kit contents	10
7.2	Preparing the kit	10
7.3	Assembling the AMD kit	11
7.4	Switching point adjustment	11
7.5	Electrical connection	12
7.6	Mounting	12
8	ELECTRICAL CONNECTION	12

LIMIT SWITCH AMM

9	INTRODUCTION	13
10	MOUNTING THE LIMIT SWITCH IN AN EXISTING EQUIPMENT	13
10.1	Kit contents	13
10.2	Preparing the kit	13
10.3	Assembling the AMM kit	14
10.4	Switching point adjustment	15
10.5	Electrical connection	15
10.6	Mounting	16
11	ELECTRICAL CONNECTION	16

TH7 TRANSMITTERS

12	INTRODUCTION	17
13	MODELS	17
13.1	TH7	17
13.2	TH7H	17
13.3	TH7T and TH7TH	17
14	MOUNTING THE TRANSMITTER IN AN EXISTING EQUIPMENT	17
14.1	Kit contents	17
14.2	Preparing the kit	18
14.3	Assembling the TH7 or TH7H kit	18
14.4	Assembling the TH7T or TH7TH kit	19
14.5	Electrical connection	19
14.6	Mounting	20
15	ELECTRICAL CONNECTION	20
15.1	Power supply and analog output	21
15.2	Digital output	21
15.3	Reset input	22
16	4-WIRE CONNECTION	22
17	HART TRANSMITTERS	23
17.1	Additional functions with HART communication	24
17.2	HART communication characteristics	24
18	"WRITE PROTECT"	25
19	ASSOCIATED SOFTWARE WINSMETER TH7	25
19.1	USB cable connection and drivers installation	25
19.2	Port connection	26
19.3	Access to Calibration and Programming	27
19.4	Visualization	29
19.5	Firmware updates	30
20	MAINTENANCE	31
20.1	Potential problems with the metering body	31
20.2	Potential problems with the indicator housing	31
20.2.1	The indicator pointer rubs on the reading scale	32
20.2.2	Deviation of the zero on the scale	32
20.3	AMD limit switch maintenance	32

20.3.1	Electrical verification	32
20.4	AMM limit switch maintenance	33
20.5	TH7 transmitter maintenance	33
21	TECHNICAL CHARACTERISTICS	33
21.1	Series DP	33
21.2	AMD limit switch	33
21.3	AMM limit switch	34
21.4	TH7 transmitter	34
21.4.1	Power supply	34
21.4.2	Outputs	34
21.4.3	General characteristics	34
22	SAFETY INSTRUCTIONS	35
22.1	Pressure equipment directive	35
22.2	Certificate of conformity TR CU (EAC marking)	35
23	ADDITIONAL INSTRUCTIONS FOR THE ATEX VERSION	36
23.1	Non-metallic parts	36
23.2	Connecting conductive parts to earth	36
23.3	Limit switch AMD	37
23.4	Limit switch AMM	37
23.5	TH7 transmitters	37
23.6	Marking	38
24	FLOW RANGES	39
25	DIMENSIONS	40
26	ATEX CERTIFICATE	42
27	DECLARATIONS OF CONFORMITY ACCORDING TO ATEX	47

SERIES DP

1 INTRODUCTION

The series DP are flowmeters for liquids and under specific conditions, for gases.

They are very robust instruments prepared to work in extreme conditions of pressure and temperature.

They have local flow rate indication by means of magnetic coupling, with scales calibrated in l/h, m³/h, kg/h, t/h, %, etc.

They can incorporate switches or electronic transmitters that allow to detect a specific flow rate and provide a flow rate signal to a remote device.

In order to operate with very low or high temperature fluids, a version with thermal separator is available.

2 WORKING PRINCIPLE

A target disk flowmeter is based on the indirect measurement of the force which is exerted on a disk suspended in the trajectory where a fluid flows at a certain speed.

The disk is held by a shaft which is perpendicular to the fluid direction, so that the force applied by it affects the shaft rotation. At the same time, a spring attached to the shaft is opposed to its turn. When the force applied on the spring is equal to the force exerted by the fluid, an equilibrium point of the turn angle of the disk, which is equivalent to a flow rate, is achieved.

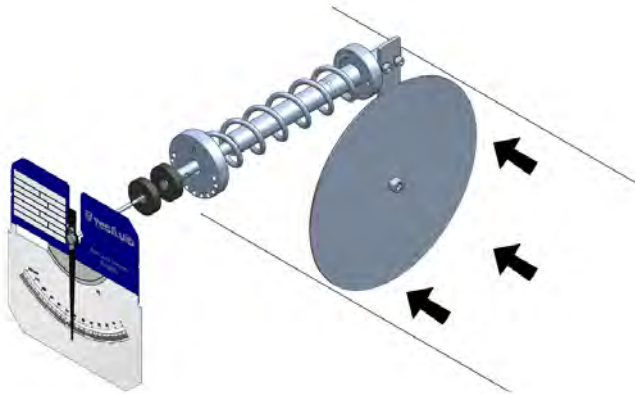

3 RECEPTION

The series DP flowmeters are supplied conveniently packaged for their protection during transportation and storage, together with their instructions manual for installation and operation.

The instruments are supplied tested in our calibration rigs, ready for installation and service.

Before installing the flowmeter, remove all the blocking elements.

With the instrument in its working position, move the disc and check that the indicating needle moves all over the scale and returns to zero.

4 INSTALLATION

For the model DP65, up to DN300, the installation is between flanges (wafer). The lower diameters, until DN80, should be mounted between loose flanges.

Model DP500, from DN250 to DN500 includes the flanges.

4.1 Straight pipe sections

In order to have stable readings, it is essential to avoid turbulences. To do this, it is necessary to install the instrument in a straight pipe section. This section should have the same inner diameter as the flowmeter. The required minimum distances upstream and downstream of the sensor are the following:

Upstream	3 DN
Downstream	3 DN

For gases these distances increase to 8 DN. These distances must be free of elements that can disturb the flow profile, such as elbows, diameter changes, valves, etc.

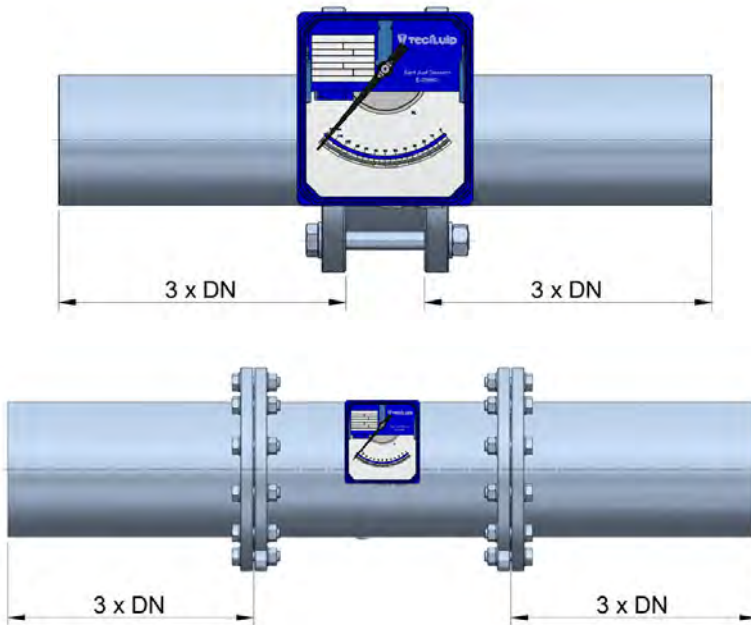

4.2 Gaskets

The gaskets should be suitable for the product and they must be carefully centered.

It is recommended that the gaskets have an internal diameter of about 5 to 10 mm bigger than the nominal flowmeter diameter. This will avoid reducing the free area when tightening the flange screws, squeezing the seal.



Any non-suitable gasket can cause reading errors or interfere with the target disk movement.

4.3 Internal diameter

The internal diameter of the pipe and the flowmeter should match. Otherwise, deviations in the flow measurement may occur.

4.4 Flow direction

The flow direction should be the same as indicated on the scale plate. The following four flow directions are available:

ED

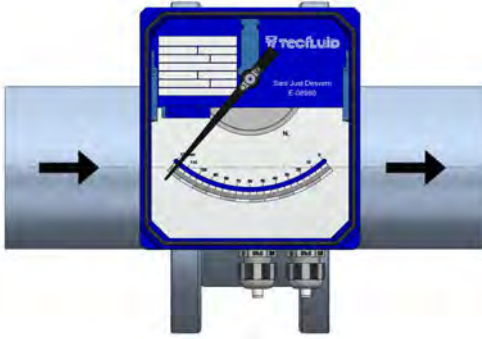

DAB



DES

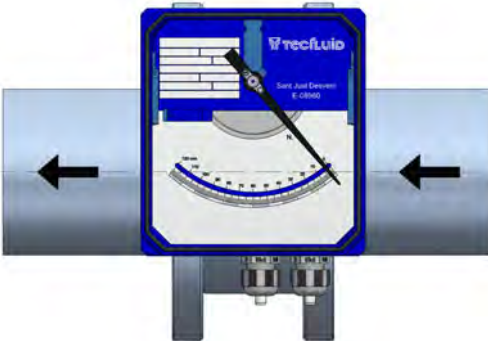

BD

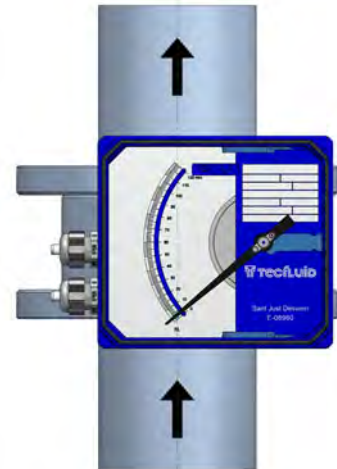

Mounting positions or flow directions different from those indicated on the scale plate can cause important reading errors or there will be no reading if the flow direction is in the opposite direction.

LIMIT SWITCH AMD

5 INTRODUCTION

The AMD limit switch can be used to generate an alarm or an operation when the flow rate that the instrument is measuring reaches a preset value on the scale plate.

The AMD limit switch consists of a NAMUR slot type inductive sensor, that is actuated by a vane. Given that there is no physical contact in the operation, the limit switch has no influence on the indicator needle movement.

An instrument can be equipped with one or two sensors, depending on the number of points to be detected. A NAMUR amplifier with a relay output can be supplied as an option.

6 OPERATION

The indicator needle moves together with the vane mounted on its shaft. When the vane enters into the slot of the sensor, the limit switch changes its state.

The sensor is mounted on a support which includes a switching point indicator that indicates the switching position. The indicator, that is below the scale plate, can be seen through the scale slot.

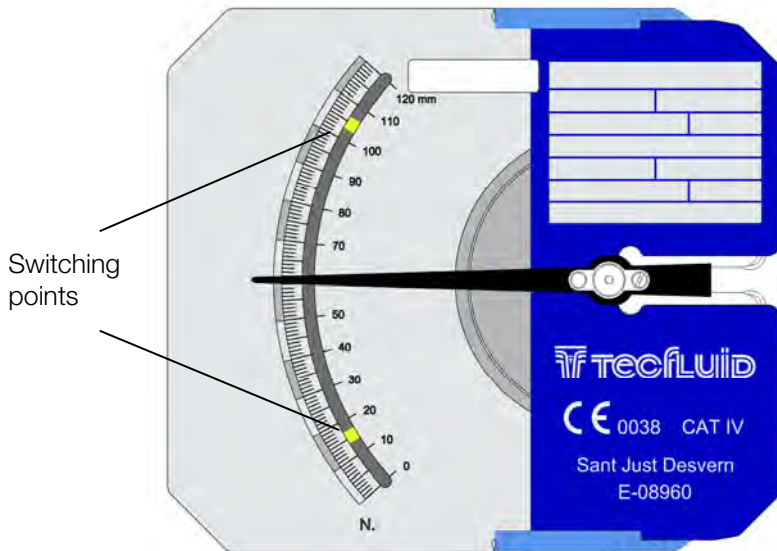

7 MOUNTING THE LIMIT SWITCH IN AN EXISTING EQUIPMENT

When the AMD limit switch is to be fitted to an existing device, please follow these steps.

7.1 Kit contents

The kit contains the following elements:

AMD kit		
Quantity	Material	Position
1	AMD limit switch circuit	1
2	Self tapping screw DIN7982 B-2,2 x 9,5 N°2 A2	2
1	Screw DIN7985 M3 x 6 A2	3
1	External tooth lock M3 A4	4
2	O-ring Ø 16 x 18,5 x 1,25 mm NBR-70	5
2	Cable gland IP68	6
2	Cable gland blanking plug	7

In the kits, the O-rings (5) and the blanking plugs (7) are not provided as loose parts. They are incorporated in the cable glands (6).

7.2 Preparing the kit

Remove the cover, unscrewing the four screws "Allen" M5 and plastic washers, in the back side of the indicator housing, using a 4 mm Allen key.

Slide the scale plate in the direction indicated in the figure, until it is released from the slot.

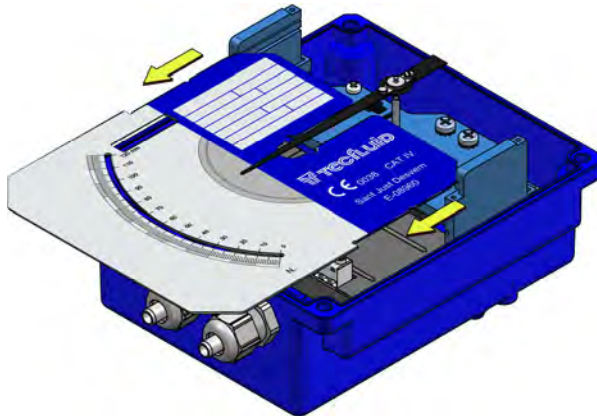

Ensure that the O-rings (5) are placed in the thread of the gland (6). If not, they should be placed. Remove the plugs from the indicator box with a flat screwdriver and replace them by the two cable glands.



The cable glands that are not expected to be used should be left with the blanking plug (7) placed to preserve watertight.

7.3 Assembling the AMD kit

Slide the circuit into the slot until it stops, and then screw it as shown in the figure.

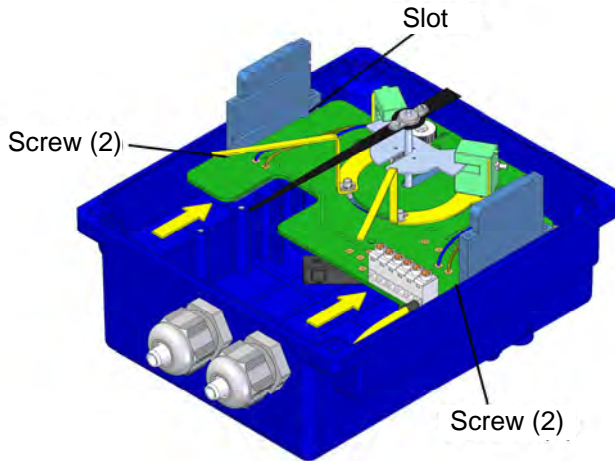

Screw the earth cable terminal with the screw (3) and tooth lock (4).

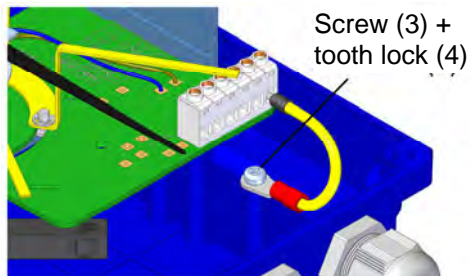

7.4 Switching point adjustment

The circular fixing nuts of the switching point are in the rear part of the indicator needle.

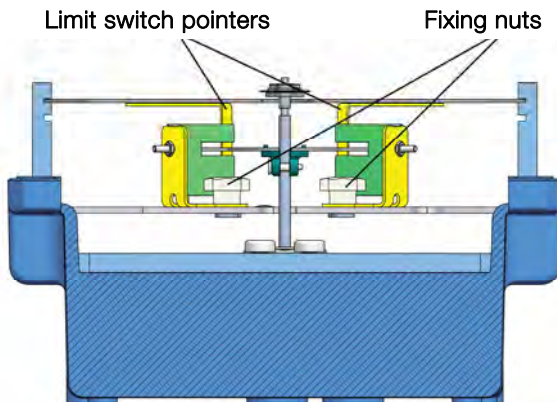

To move the limit switch needle, the circular fixing nuts have to be slightly loosen by turning them to the left, without removing the scale plate (see the figure on the next page). After that, place the switching point indicator in the required scale value, and fix it again with the screw.

As standard, when the instrument has one AMD, it comes configured as a minimum limit switch.

7.5 Electrical connection

Do it according to section 8.

7.6 Mounting

Slide the scale plate into the slot until it stops as shown in the figure. Mount the cover with the four screws "Allen" M5 and the plastic washers.

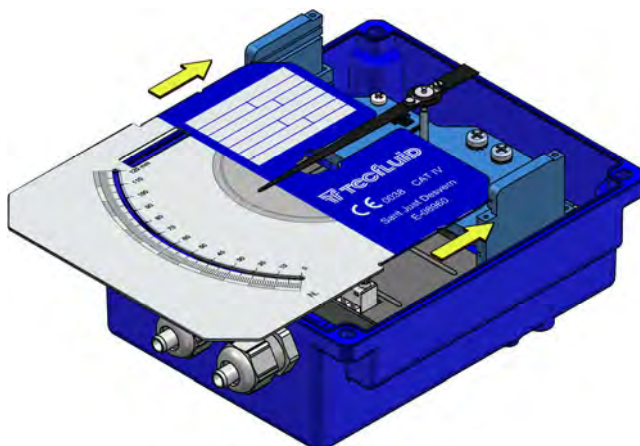

8 ELECTRICAL CONNECTION

To gain access to the electrical terminal block, the scale plate must be removed. To do this, slide it to the left by the guide and free it.

In order to make the electrical connection of the instrument, the limit switch has a screw terminal strip.

For the electrical installation it is recommended to use multiple conductor cables with individual cable sections in the order of 0.25 to 0.5 mm² in order to make it easier to connect.

Before starting the installation, check that the cable glands are the right size for the cables to be used, this will guarantee the instrument will stay watertight. The supplied M16 cable glands are for cables with outside diameters between 6 mm and 10 mm.

Peel the outside insulation to free the inner cables. It is recommended to tin the ends of the wires to avoid loose ends. Next, feed the cables through the cable glands, and connect to the corresponding screw terminals. Last, tighten up the cable glands so that they maintain their ingress protection.

The numbering of the terminals is given on the printed circuit board.

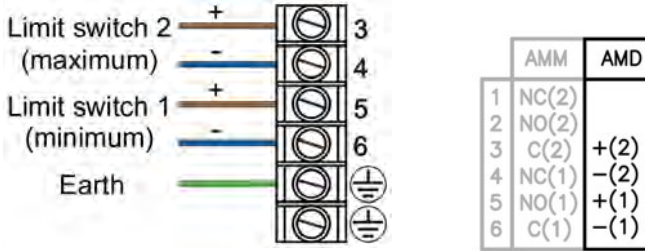

LIMIT SWITCH AMM

9 INTRODUCTION

The AMM limit switch can be used to generate an alarm or an operation when the flow rate or the instrument is measuring reaches a preset value on the scale plate.

It consists of a micro-switch driven by a cam mounted on the indicating needle.

An instrument can be equipped with one or two micro-switches, depending on the number of points to be detected.

10 MOUNTING THE LIMIT SWITCH IN AN EXISTING EQUIPMENT

In order to add an AMM limit switch to an existing device, follow the steps shown below.

10.1 Kit contents

The kit contains the following elements:

AMM kit		
Quantity	Material	Position
1	AMM limit switch circuit	1
2	Self tapping screw DIN7982 B-2,2 x 9,5 N°2 A2	2
1	Screw DIN7985 M3 x 6 A2	3
1	External tooth lock M3 A4	4
2	O-ring Ø 16 x 18,5 x 1,25 mm NBR-70	5
2	Cable gland IP68	6
2	Cable gland blanking plug	7

In the kits, the O-rings (5) and the blanking plugs (7) are not provided as loose parts. They are incorporated in the cable glands (6).

10.2 Preparing the kit

Remove the cover, unscrewing the four screws "Allen" M5 and plastic washers, in the back side of the indicator housing, using a 4 mm Allen key.

Slide the scale plate in the direction indicated in the figure, until it is released from the slot.
Ensure that the O-rings (5) are placed in the thread of the gland (6). If not, they should be placed. Remove the plugs from the indicator box with a flat screwdriver and replace them by the two cable glands.



The cable glands that are not expected to be used should be left with the blanking plug (7) placed to preserve watertight.

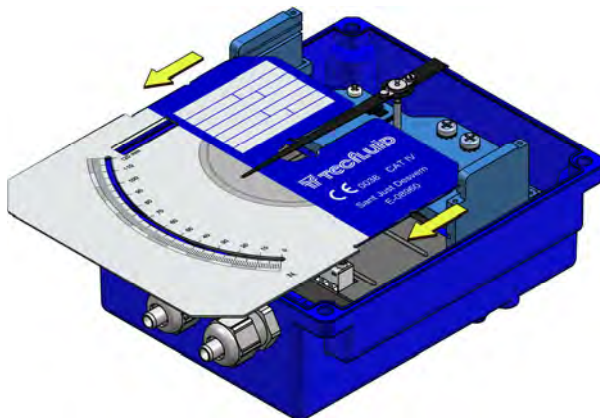

10.3 Assembling the AMM kit

Slide the circuit into the slot until it stops, and then screw it as shown in the figure.

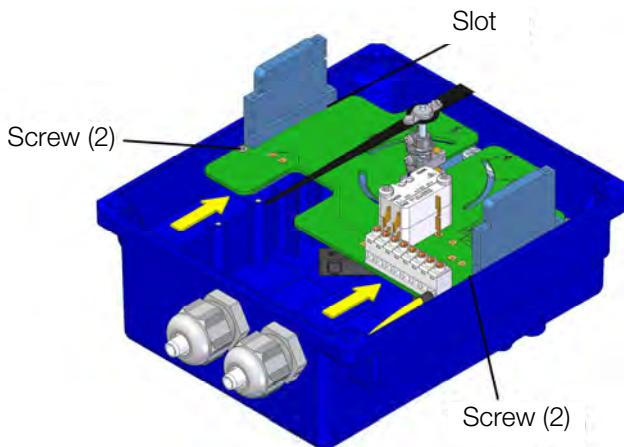

Screw the earth cable terminal with the screw (3) and tooth lock (4).

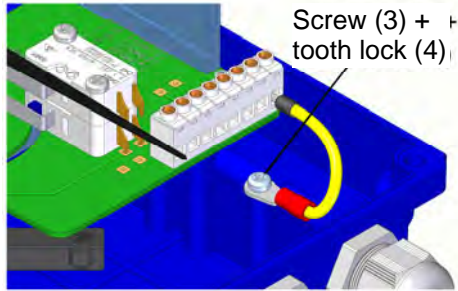

10.4 Switching point adjustment

To adjust the switching point, loosen slightly the cam's grub screw (C) and turn the cam on the shaft until the required switching point is achieved.

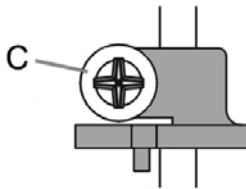

To turn the cam on the shaft, do not hold the shaft by the indicating needle, as this may move the needle on the shaft. The shaft should be held directly.

For the models DP/BD and DP/DES, if the cam is turned in the "A" direction, the acting point will move away from the zero point of the scale. If the cam is turned in the "B" direction, the acting point will move towards the zero point of the scale.

For the models DP/DAB and DP/ED, if the cam is turned in the "A" direction, the acting point will move towards the zero point of the scale. If the cam is turned in the "B" direction, the acting point will move away from the zero point of the scale.

Once the cam is in its position, making sure that it rests on the follower of the micro-switch lever, and the grub screw (C) has been tightened, the correct working of the limit switch should be verified by turning the indicating needle shaft and checking the switching at the required point.

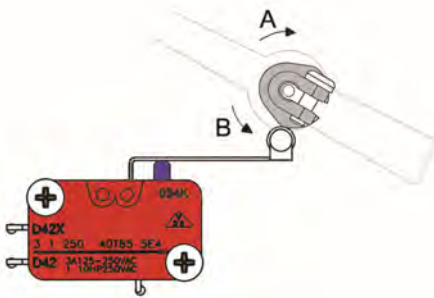

Cam shown acting on the micro-switch lever

10.5 Electrical connection

Do it according to section 11.

10.6 Mounting

Slide the scale plate into the slot until it stops as shown in the figure. Mount the cover with the four screws "Allen" M5 and the plastic washers.

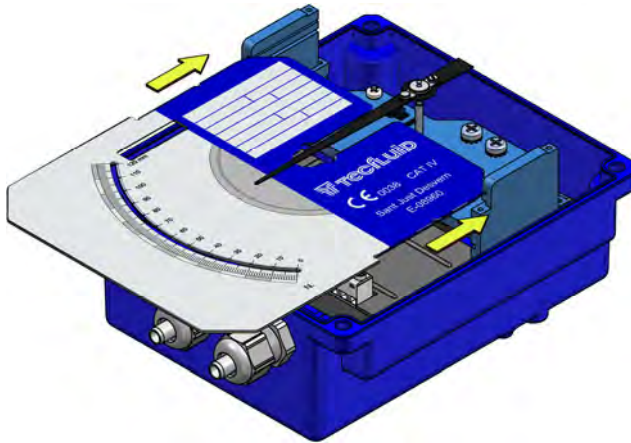

11 ELECTRICAL CONNECTION

In order to make the electrical connection of the instrument, the limit switch has a screw terminal strip.

For the electrical installation it is recommended to use multiple conductor cables with individual cable sections in the order of 0.25 to 0.5 mm² in order to make it easier to connect. Loose cables should not be used given that they can affect the seal of the cable glands. It is better to maintain the mains cables separated from the cables with low level signals.

Before starting the installation, check that the cable glands are the right size for the cables to be used, this will guarantee the instrument will stay watertight. The M16 cable glands used are for cables with outside diameters between 6 mm and 10 mm.

Peel the outside insulation to free the inner cables. It is recommended to tin the ends of the wires to avoid loose ends. Next, feed the cables through the cable glands, and connect to the corresponding screw terminals. Last, tighten up the cable glands so that they maintain their ingress protection.

The numbering of the terminals is given on the printed circuit board.

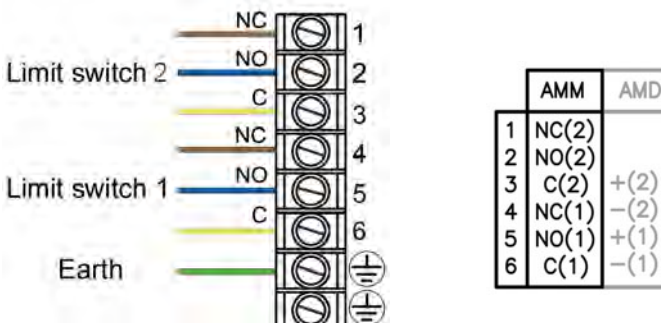

TH7 TRANSMITTERS

12 INTRODUCTION

TH7 transmitters are microprocessed electronic position transducers. The instrument uses the Hall effect to capture the field of a magnet. The resulting signal, after the micro-controller processing, is converted into a current signal of 4-20 mA in a 2-wire loop. This signal is proportional to the flow rate.

13 MODELS

13.1 TH7

It is a 4 to 20 mA transmitter proportional to flow rate that incorporates a digital output configurable as synchronized pulse output or alarm output. 4 mA corresponds to beginning of the scale. 20 mA corresponds to full scale.

The cut off value can be programmed (see section 19.3 in page 29). By default, the cut off corresponds to the first point on the scale after the zero point.

13.2 TH7H

It is a TH7 transmitter that incorporates HART protocol compatibility. With this protocol the user can change the measuring range of the 4-20 mA loop, and data like flow rate and accumulated volume.

13.3 TH7T and TH7TH

They are the equivalent models to those of the sections 13.1 and 13.2, but in addition they include a 8-digit totalizer (7 entire numbers and 1 decimal).

14 MOUNTING THE TRANSMITTER IN AN EXISTING EQUIPMENT

When the transmitter is to be fitted to an existing device, please follow these steps.

14.1 Kit contents

The kit contains the following elements:

Kit TH7 or TH7H		
Quantity	Material	Position
1	Transmitter	1
4	Screw DIN7985 M 3 x 4 A2	2
2	O-ring Ø 16 x 18,5 x 1,25 mm NBR-70	3
2	Cable gland IP68	4
2	Cable gland blanking plug	5

Kit TH7T or TH7TH		
Quantity	Material	Position
1	Totalizer	1
2	Screw DIN7982 B-2,2 x 9 N°2 A2	2

In the kits, the O-rings (3) and the blanking plugs (5) are not provided as loose parts. They are incorporated in the cable glands (4).

14.2 Preparing the kit

Remove the cover, unscrewing the four screws "Allen" M5 and plastic washers, in the back side of the indicator housing, using a 4 mm Allen key.

Slide the scale plate in the direction indicated in the figure, until it is released from the slot.

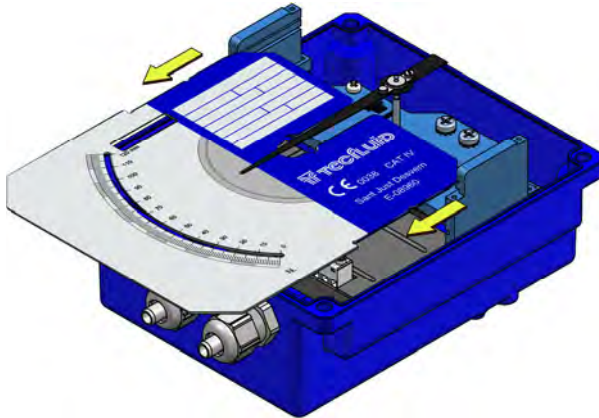

Ensure that the O-rings (3) are placed in the thread of the gland (4). If not, they should be placed. Remove the plugs from the indicator box with a flat screwdriver and replace them by the two cable glands.



The cable glands that are not expected to be used should be left with the blanking plug (5) placed to preserve watertight.

14.3 Assembling the TH7 or TH7H kit

Screw the transmitter as shown in the figure.

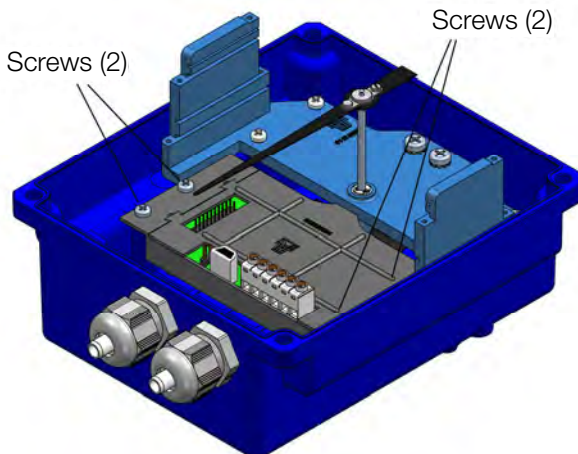

14.4 Assembling the TH7T or TH7TH kit

Slide the circuit through the slot until it stops, and then screw it as shown in the figure.

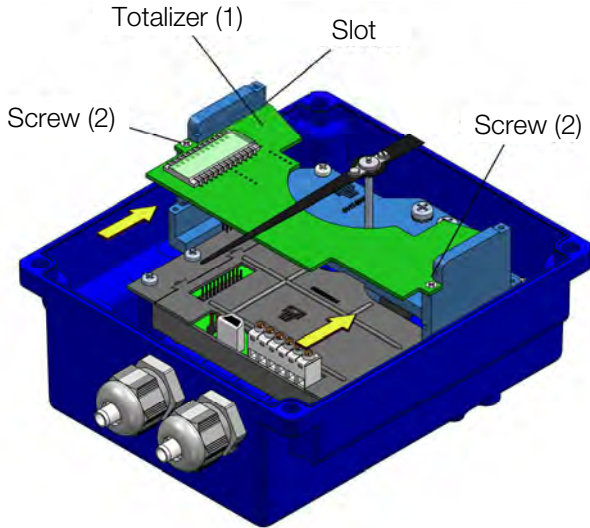

The flat ribbon connecting the transmitter to the totalizer should be connected as in the figure below.

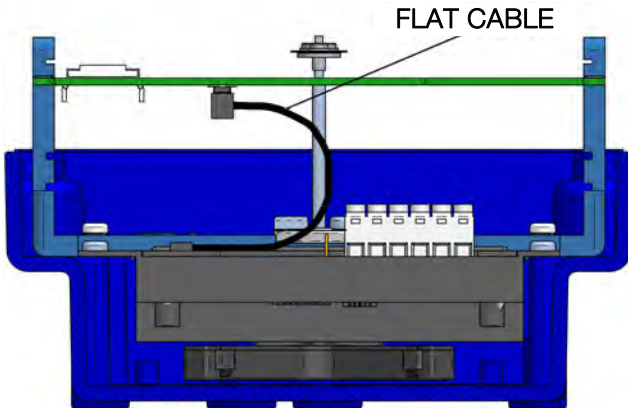

14.5 Electrical connection

Do it according to section 15.

14.6 Mounting

Slide the scale plate into the slot until it stops as shown in the figure. Mount the cover with the four screws "Allen" M5 and the plastic washers.

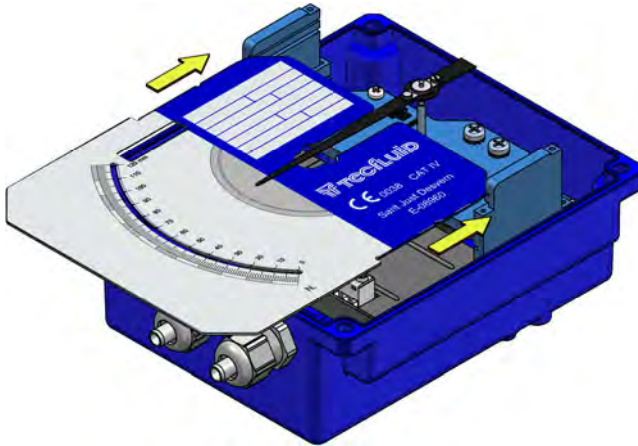

15 ELECTRICAL CONNECTION

For the electrical connection, the transmitter has a screw terminal strip.

For the electrical installation it is recommended to use multiple conductor cables with individual cable sections in the order of 0.25 to 0.5 mm² in order to make it easier to connect.

A twisted pair wiring should be used to avoid electrical interferences in the 4-20 mA loop. In some instances, shielded cable may be necessary.

Before starting the installation, check that the cable glands are the right size for the cables to be used, this will guarantee the instrument will stay watertight. The M16 cable glands used are for cables with outside diameters between 6 mm and 10 mm.

Peel the outside insulation to free the inner cables. It is recommended to tin the ends of the wires to avoid loose ends. Pass the cables through the cable glands and screw down in the corresponding positions of the terminal strip. Once the wiring is finished make sure that the cables are well gripped by the cable glands to maintain the ingress protection.



The cable glands must be always closed. Entry of dust or some types of vapours can damage the internal system of bearings and therefore the equipment.

To help in the wiring of the equipment, the description of the terminals is marked on the printed circuit next to the terminal strip.

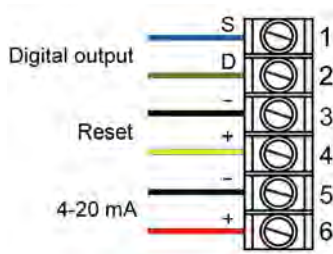



Before connecting the power supply, you must be sure that the supply voltage is the correct one for the installation. The power supply voltage is indicated on the label of the transmitter.

15.1 Power supply and analog output

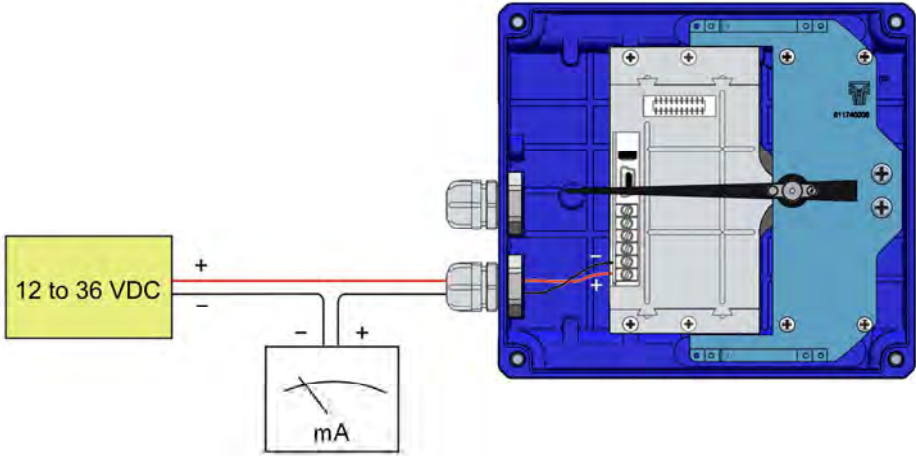

The connection is made in the terminal block. The positive terminal of the power supply is connected to the position + and the positive terminal of the load is connected in the position -. The negative terminals of the power supply and the load are connected together. The instrument works in a 2-wire system, that is, the supply and signal line is the same. It is recommended to use a twisted pair wiring or shielded cable to avoid interferences in the current loop.

15.2 Digital output

The digital output is connected in the positions D and S of the terminal block. The output is an N channel MOSFET transistor isolated from the rest of the circuit and potential free. The S terminal is the source and the D terminal is the drain.

By means of the Winsmeter TH7 software, the digital output can be programmed as pulse output or alarm output (see section 19.3 in page 29).

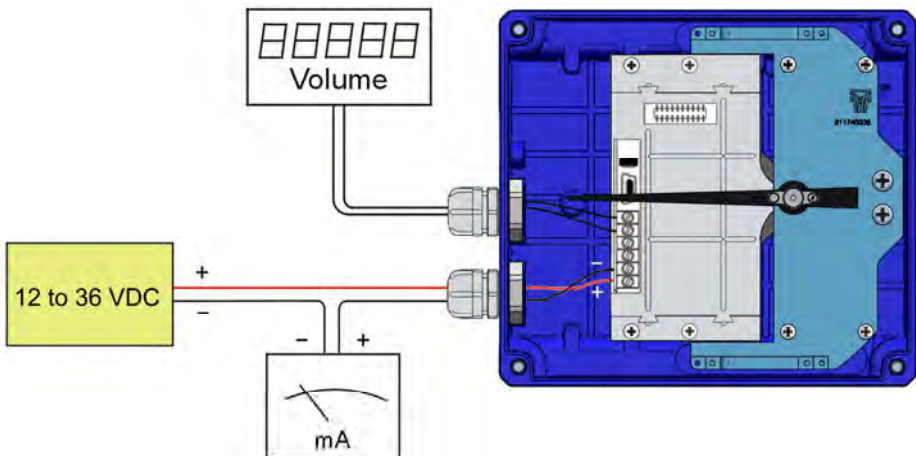

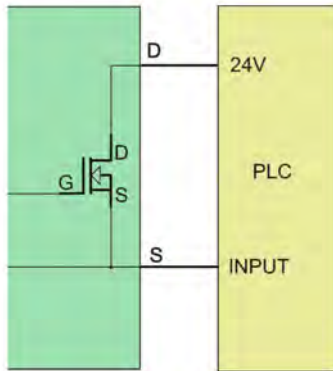

Example of the connection of the pulse output to a PLC

15.3 Reset input

The terminals marked as RESET are a reset input for the totalizer. It can be connected to a normally open potential free contact. It is important that the contact works well with low level signals, to avoid noise effects.



Note: The reset terminals are not isolated from the rest of the circuit. They must not be connected to other equipment.

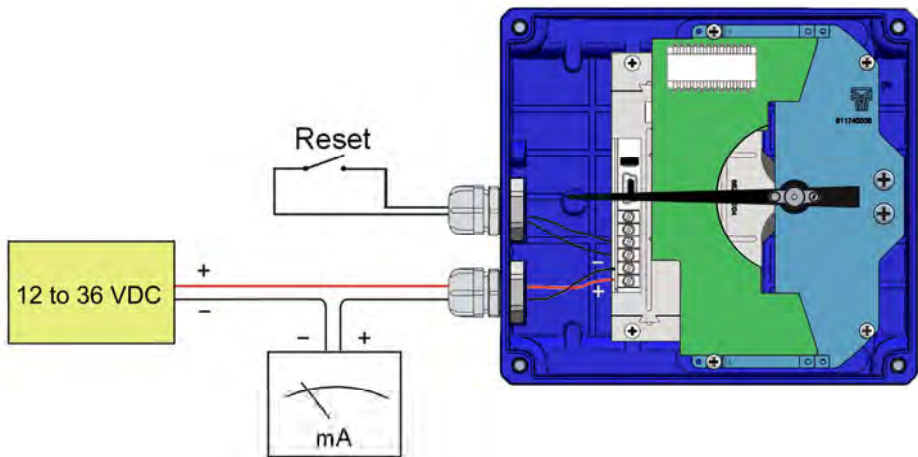

16 4-WIRE CONNECTION

If direct current power supply for the transmitter is not available in the installation, it will be necessary to incorporate an additional power supply as in the following figure.

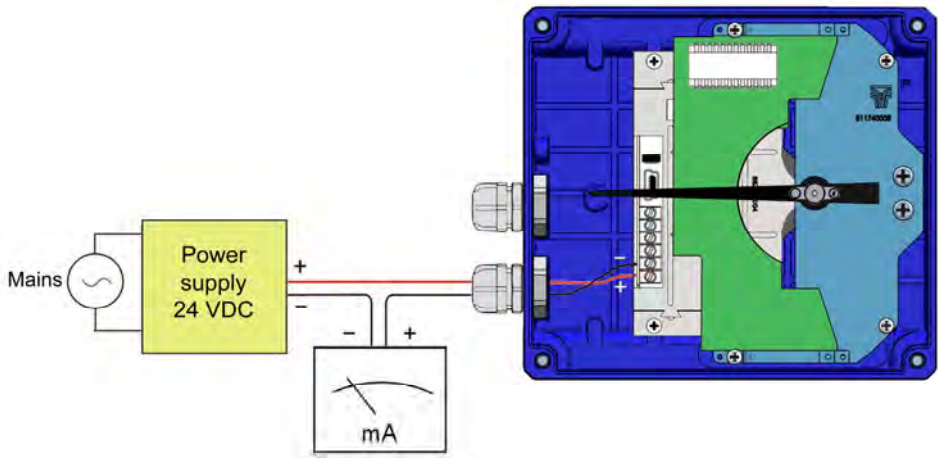

17 HART TRANSMITTERS

The TH7H and TH7TH transmitters have a modem for HART communication.

TH7H transmitters are fully compatible with the **HART Server** software from HART Communication Foundation.



Tecfluid S.A. do not guarantee that the TH7H transmitter is compatible with the different servers on the market.

When connecting the transmitter, an external resistor ($R_{ext.}$) should be included. Its minimum value needs to be 200 Ω , and the maximum value depends on the power supply as follows:

$$R(\text{Ohm}) = \frac{V - 14}{20 \cdot 10^{-3}}$$

In this case the power supply voltage needs to be 18 VDC minimum.

In order to establish HART communication, it is necessary to connect a terminal or PC with a HART modem, in one of the points indicated in the following figure.

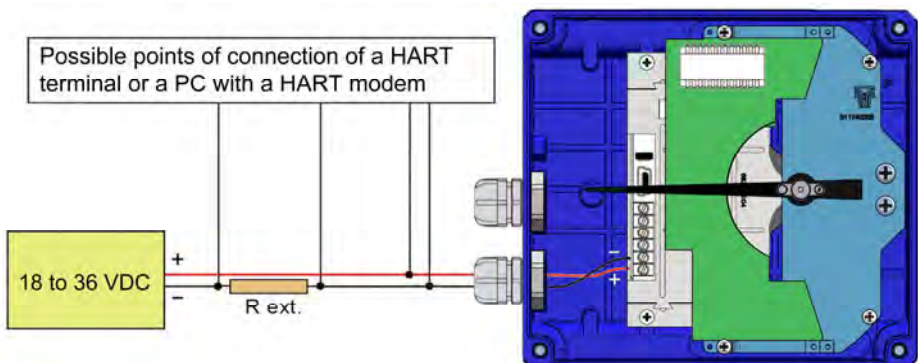

17.1 Additional functions with HART communication

By means of the implemented commands, the user can obtain the following information:

- Flow rate value in the scale units
- Totalizer value (even if the equipment does not have a display).
- Reset or writing of a totalizer value.
- Change of beginning and end of scale of the current loop.
- Possibility of writing tags and messages into the instrument.

17.2 HART communication characteristics

The detail of the characteristics with respect to the HART communication are available in the corresponding "Field Device Specification" document.

Summary of the main communication characteristics:

Manufacturer, Model and Revision	Tecfluid S.A., TH7H, Rev. 0
Device type	Transmitter
HART revision	6.0
Device Description available	No
Number and type of sensors	1
Number and type of actuators	0
Number and type of host side signals	1, 4 – 20 mA analog
Number of Device Variables	2
Number of Dynamic Variables	1
Mappable Dynamic Variables	No
Number of Common Practice Commands	5
Number of Device Specific Commands	0
Bits of Additional Device Status	12
Alternative working modes?	No
Burst mode?	No
Write Protection?	Yes

Electrical characteristics referred to the analog loop and communications:

Reception impedance:

Rx	>	3,3 M Ω
Cx	<	1000 pF

18 “WRITE PROTECT”

The instrument has a jumper that can be used to avoid changes in the configuration. When the jumper is connected the instrument can be configured via HART. When the jumper is removed, “Write Protect” is activated for HART, thus avoiding any changes in the configuration.

19 ASSOCIATED SOFTWARE WINSMETER TH7

By means of this associated software the transmitter can perform the following functions, working in a comfortable and intuitive way.

- Complete re-calibration of the transmitter according to the scale of the instrument.
- Programming of 4 and 20 mA values
- Filter and cut off programming
- Totalizer reset or adjustment of a desired value
- Configuration of the digital output as pulse output or alarm

Such software can be downloaded from section “Downloads” of the Tecfluid S.A. website.

19.1 USB cable connection and drivers installation

Extract the files from the winsmeterTH7.zip to a new system folder.

Execute the Setup.exe file and follow the steps for the installation.

In order to connect the converter to a computer an USB cable is required. This cable is type A at one end and mini USB type B at the other (cable not supplied).

The ends of the cables can be seen in the picture.



The first step to make the connection is to open the cover of the indicator housing by removing the four screws "Allen" M5 and plastic washers on the back of the housing.

After removing the graduated scale plate sliding it through the slots, the USB connector is visible at the bottom of the housing.

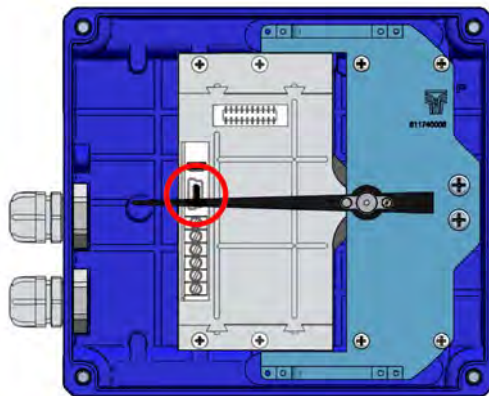

Connect the USB cable at one end to the transmitter and at the other to the computer where the software is installed.

Power on the electronic converter.

Execute the program WinsmeterTH7 following the sequence Start – Programs – Tecfluid S.A. - WinsmeterTH7.

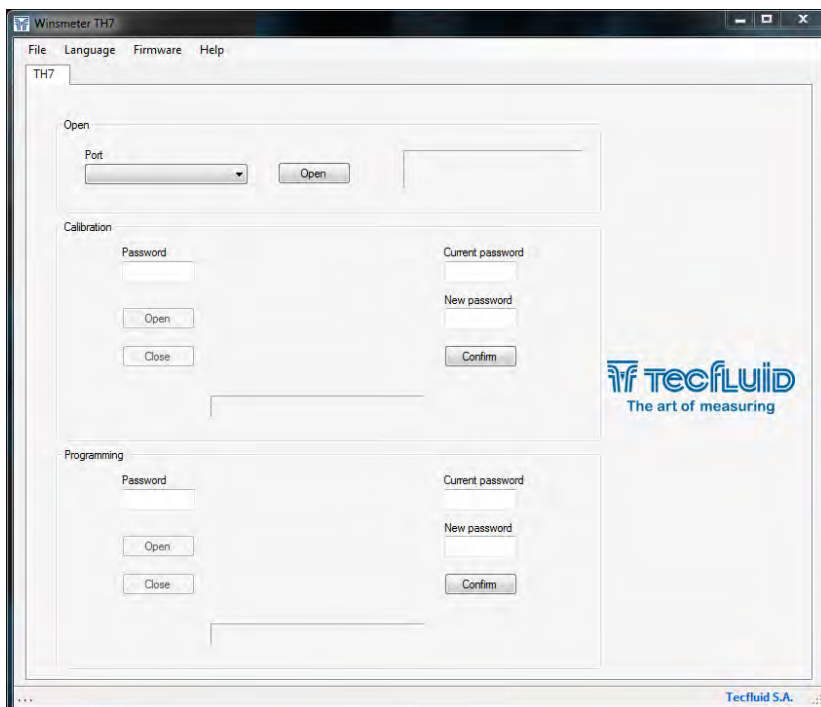

19.2 Port connection

In the "Port" section, choose the appropriate port for the converter. This will appear with the name of the port followed by TH7 and its serial number. Then click "Open".

Once the port is open, the button "Open" in the "Calibration" and "Programming" sections activates.

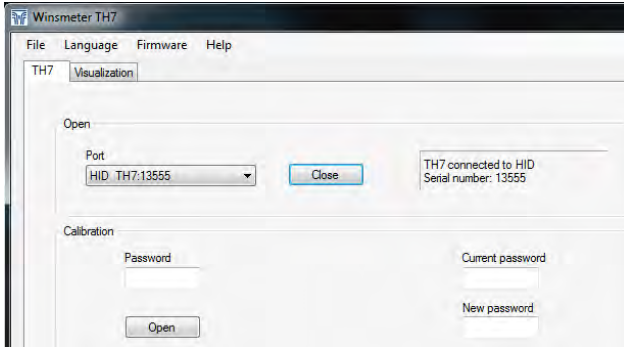

19.3 Access to Calibration and Programming

In order to change data in the tab "Calibration", you must enter a password.

The default password is **calib**, and it can be changed using the boxes on the right of the "Calibration" section.

Likewise, to change data in the tab "Programming" it is necessary to enter the password which by default is **program**. This can be changed using the boxes on the right of the "Programming" section.

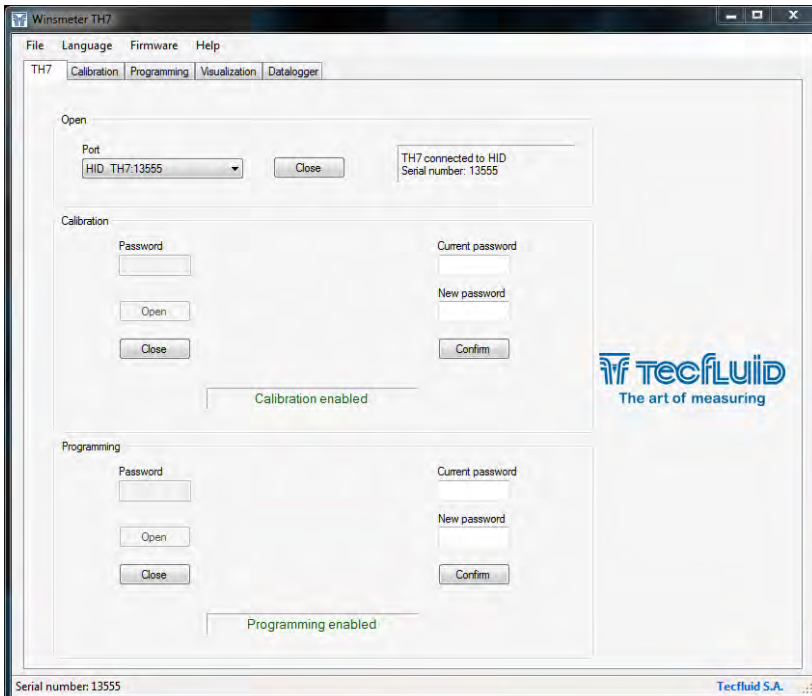

Once the password is written, press "Enter" or "Open", and all controls from the Calibration or Programming window will be modifiable. At the bottom of each section the text "Calibration tab enabled" or "Programming tab enabled" will be displayed

To enter the Installation window, just click the corresponding tab.

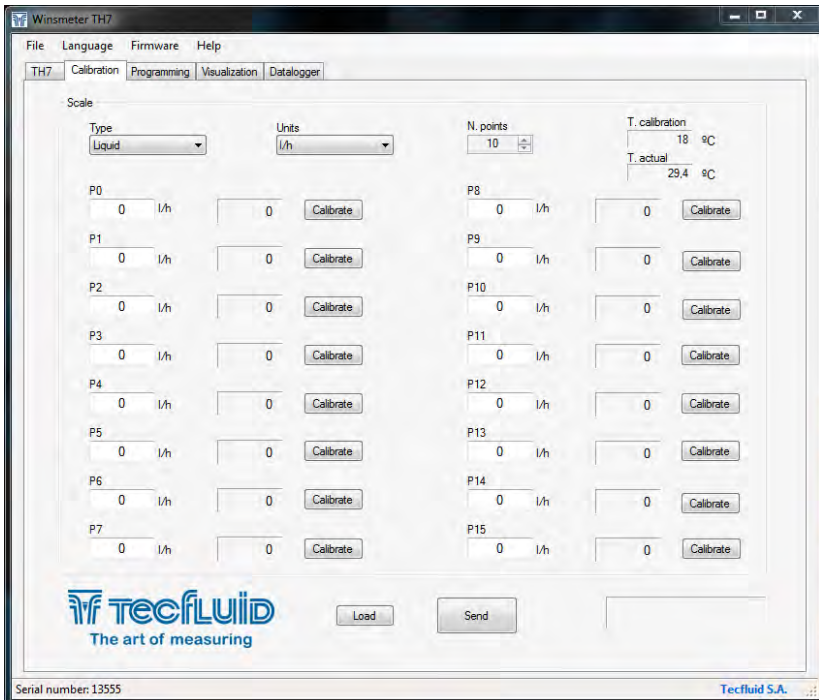

In the calibration window a complete re-calibration of the transmitter according to the scale plate can be done.

The first step is to choose the scale units, then the specific units.

In the combo **N. points** the number of points with which the calibration will be performed is selected. The minimum is 10 and the maximum 16.

With these data, the boxes P0 ... P10 to P16 are filled with the values of the scale in which the adjustment will be made.

To perform the calibration, the instrument must be in its operating position.

Depending on the instrument in question, move the float or the disc until the needle points each calibration point, and press the "Calibrate" button of the corresponding point.

Once calibrated every point, to send all the data to the transmitter TH7, click the "Send" button. The data is then stored in the transmitter memory.

Likewise, to enter into the programming window, just click the corresponding tab.

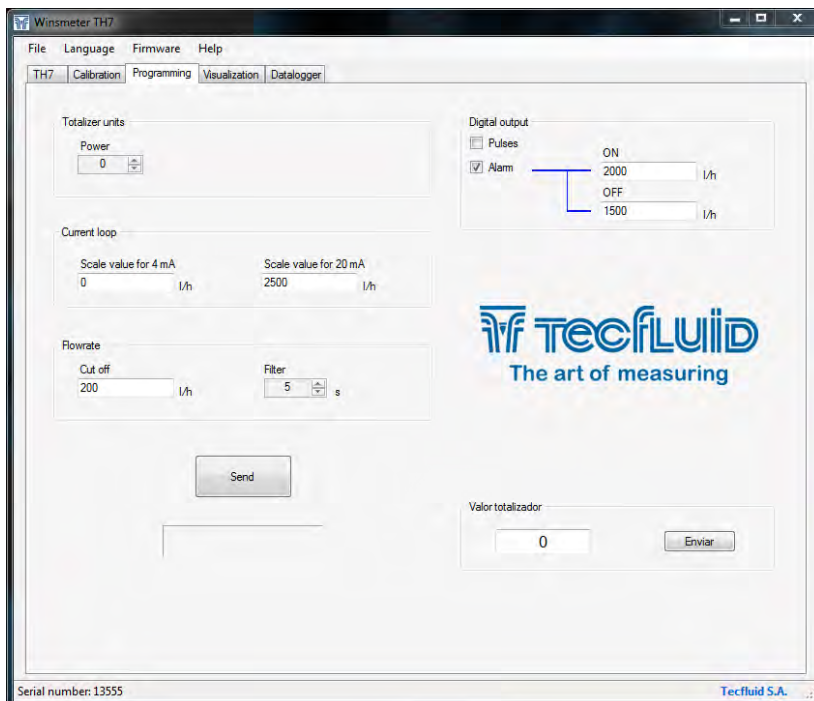

Changing the parameters of this screen, (see previous page) you can program the different functions of the equipment.

In the box **Totalizer units** power can be selected. The power allows to multiply or divide by a factor the totalizer speed, as well as the pulse output.

In the box **Digital output** this output can be configured as pulse output or as alarm. In the latter case, the activation and deactivation values for the alarm can be programmed.

In the box **Current loop** the values of flow rate equivalent to 4 and 20 mA can be programmed. These values do not have to be the beginning of scale and end of scale values.

In the box **Flow rate** the values of cut off and filter can be changed.

To program this data to the transmitter, press the "Send" button. The programming data will be stored in the memory of the transmitter.

Regardless of the programming process, in the box **Totalizer value** the value of the totalizer can be changed.

19.4 Visualization

When the communication with the computer port is established (see section 20.2), the tab "Visualization" opens. This tab lets you view real-time flow rate, totalizer and velocity values, as well as the current value of the analog output and the status of the digital output if configured as alarm.

It is an intuitive tool to verify that the instrument has been installed and programmed correctly.

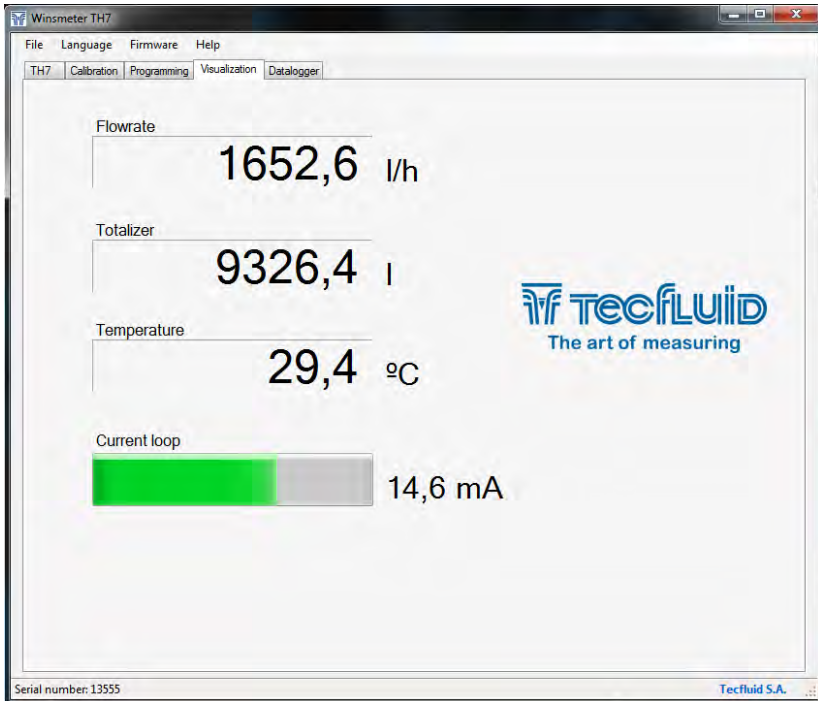

19.5 Firmware updates

New firmware updates can be published in the website. These updates contain improvements or bug fixes that make the equipment operates at best conditions.

The updates can be downloaded from the section "Downloads" of Tecfluid S.A. website

To update the equipment, go to menu "Firmware" - "Update", and a screen with the button "File" will appear. Pressing this button system can be accessed. The downloaded file has to be searched there.

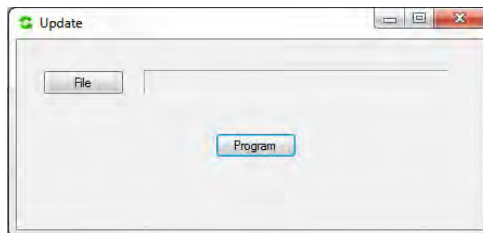

Once the file is selected, press the “Program” button. A message “Programming device” will appear.

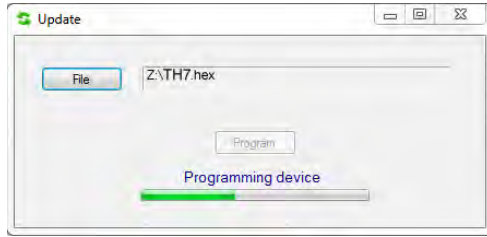

The process takes about 90 seconds, after which the message “Device programmed” will appear.

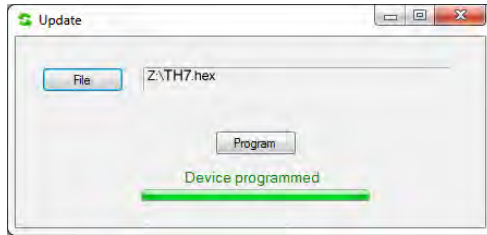

From this moment, the transmitter already has the new version of Firmware.

20 MAINTENANCE

20.1 Potential problems with the metering body

The following faults may occur:

- Magnetic coupling deterioration
- Deterioration of the torsion or reading spring
- Wearing out of torsion shaft bearings
- Wearing out or deterioration of the lever and target disk

If any of these breakdowns occurs, it is preferable to repair it in TECFLUID S.A. facilities, as a new calibration will be normally necessary.

20.2 Potential problems with the indicator housing

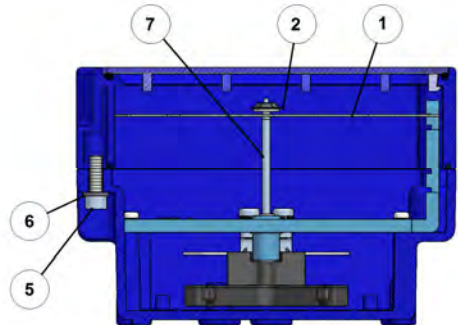
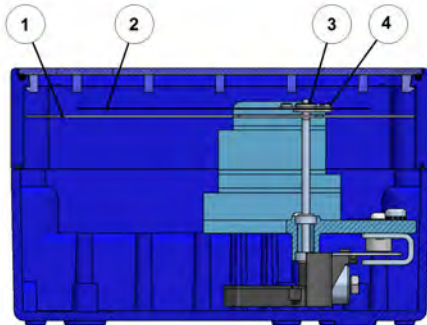

20.2.1 The indicator pointer rubs on the reading scale

To remove the cover, remove the four screws "Allen" M5 and plastic washers, in the back side of the indicator housing, using a 4 mm Allen key.

Rubbing normally happens if the meter has been hit or dropped. Simply straighten the pointer (2) by bending it slightly until it is separated between 2-3 mm from the reading scale surface (1)

20.2.2 Deviation of the zero on the scale

When the indicator pointer (2) does not point zero in its rest position, place the flowmeter in its real working position on top of a non-magnetic table. If when the float is moved the pointer moves but does not return to 0, check that the pointer hub (3) is firmly attached to the pointer shaft (7). If it isn't, secure the pointer hub (3) onto the conical tip (7) of the shaft by tapping it lightly and carefully.

If the pointer hub is fixed, make the indicator pointer coincide with the 0 on the scale using the frontal adjusting screw (4) on the indicator pointer. Make sure that the shaft (7) is held fast so as not to be bent or damaged

Check that there is no rubbing between the pointer movement system and the cables connected to a limit switch or transmitter.

20.3 AMD limit switch maintenance

20.3.1 Electrical verification

Check that the voltage at the terminals + and - is over 7.5 V when the vane is in the slot. Connect a multimeter with the scale in DC mA, in series with the terminal +.

Verify that the current is less than 1 mA when the vane is in the slot, and more than 3 mA when the vane is out of the slot.

If you do not have the NAMUR amplifier, the current can be checked using the following circuit diagram:

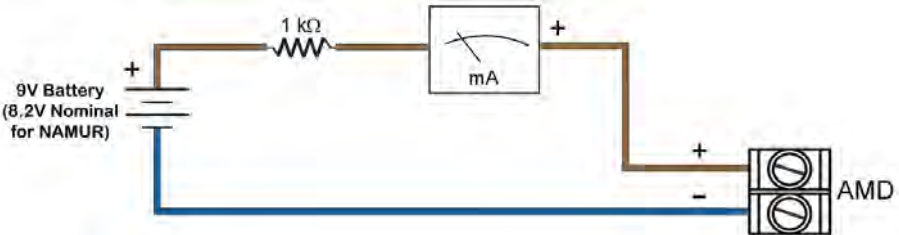

If you do not have the AMD sensor, the operation of the amplifier can be checked using the following circuit diagram:

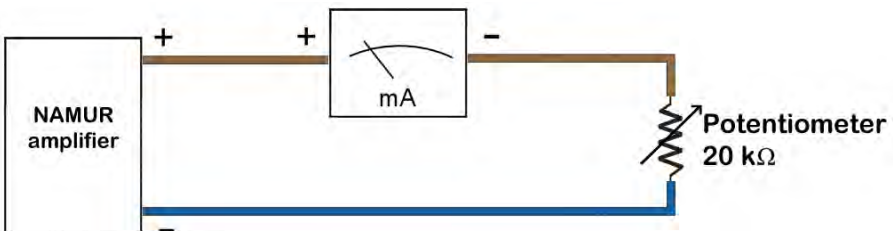

With the potentiometer the current of the NAMUR amplifier can be modified. The switching point must be between 1.2 mA and 2.1 mA. That is, with the current below 1.2 mA the output relay must have a state and above 2.1 mA the output relay must have the other state.

20.4 AMM limit switch maintenance

No special maintenance is required.

20.5 TH7 transmitter maintenance

No special maintenance is required.

21 TECHNICAL CHARACTERISTICS

21.1 Series DP

Accuracy	DP65: $\pm 2,5\%$ full scale DP500: $\pm 4\%$ full scale
Scales	Direct in engineering units or in %
Mounting length	DP65: 65 mm DN40 ... DN300 DP500: 500 mm DN250 ... DN300 600 mm DN350 ... DN400 700 mm DN500
Working temperature	
Body in coated steel:	-20°C ... +150°C
Body in EN 1.4404 (AISI 316L), bearing in PTFE:	-20°C ... +150°C
Body in EN 1.4404 (AISI 316L), bearing in bronze:	-20°C ... +300°C
With thermal separator (body in steel or EN 1.4404 (AISI 316L):	
With electronics:	DN40 ... DN100: +400°C DN125 ... DN150: +320°C DN200 ... DN300: +280°C DN350 ... DN500: +250°C
Without electronics:	DN40 ... DN500: +400°C
Working pressure	PN40 DN40 ... DN80 PN16 DN100 ... DN300 PN10 DN250 ... DN500 (DP500) Other pressures on request
Connections	DP65 Between flanges (wafer) DP500 EN 1092-1 flanges, ANSI, JIS Others on request
Housing	IP65 - coated aluminium IP65 - PP IP67 - EN 1.4404 with glass window, on request

21.2 AMD limit switch

Nominal voltage	8 V
Working voltage	5 ... 25 V
Power supply internal resistance	1 k Ω
Current with the vane into the slot	< 1 mA
Current with the vane out of the slot	≥ 3 mA
Standard:	DIN EN 60947-5-6 (NAMUR)
Ambient temperature	-25°C ... +100°C

21.3 AMM limit switch

Maximum switching voltage	250 VAC
Maximum switching current	3 A
Potential free SPDT contacts	
Ambient temperature	-25°C ... +100°C

21.4 TH7 transmitter

21.4.1 Power supply

2-wire

Minimum voltage (TH7 and TH7T): 0.02 Z + 12 (Volt) (Z is the load in the current loop in Ohm)

The minimum value is 12 VDC for Z=0 Ohm

Minimum voltage (TH7H and TH7TH): 0.02 (Z+Rext) + 14 (Volt) (Z is the load in the current loop in Ohm)

The minimum value is 18 VDC for Z=0 Ohm and Rext=200 Ohm

Maximum voltage: 36 VDC

Consumption: maximum 20 mA

21.4.2 Outputs

Analog output: 4 - 20 mA, factory calibrated

Maximum load in the 4-20 loop: 1.1 kΩ (at 36 VDC supply voltage)

Pulse output: MOSFET transistor N channel potential free

I_{max}: 200 mA

Maximum frequency: 6 Hz

Pulse duration: Approx. 62.5 ms

Pulse / units of volume or mass depending on the scale; factory adjustable or by means of Winsmeter software

Totalizer: 8 digits. (7 + one decimal. Reset by means of potential free contact)

21.4.3 General characteristics

Accuracy (analog output with respect to the magnetic field):

< 0.6 %

Ambient temperature:

-20°C ... +70°C

Cable gland:

M16 x 1.5

22 SAFETY INSTRUCTIONS

The series DP flowmeters are in conformity with all essential requirements of all EC directives applicable to them:

2014/68/EU Pressure equipment directive (PED)



Limit switches and transmitters:

2014/30/EU Electromagnetic compatibility directive (EMC)

2012/19/EU Waste electric and electronic equipment (WEEE).



Limit switch AMM:

2014/35/EU Low voltage directive (LV)

Equipment for hazardous areas:

2014/34/EU Equipment and protective systems intended for use in potentially explosive atmospheres (ATEX).



In the last sections of this manual the EC type certificate and the declarations of conformity according to the ATEX directive are attached.

Other declarations of conformity EC can be downloaded from the section "Download" of the Tecfluid S.A. website.

22.1 Pressure equipment directive

Tecfluid S.A. have subjected the series DP of flowmeters to a conformity assessment method for the pressure equipment directive, specifically according to module H (full quality assurance).

Conformity with the directive is reflected by the CE marking in each pressure equipment and by the written declaration of conformity. The CE marking is accompanied by the identification number of the notified body involved at the production control phase.

The marking of the equipment takes into account the fluid type, the group of fluid and the category, for example: G1 CATII

G Gases and vapours

1 Group of liquids 1

CATII Category II

Devices that, due to their size, are rated as Category I are not within the scope of the directive and therefore they have not the CE mark according to pressure directive. These devices are subject to applicable sound engineering practice (SEP).



This equipment is considered as being a pressure accessory and **NOT** a safety accessory as defined in the 2014/68/EU directive, Article 2, paragraph 4.

22.2 Certificate of conformity TR CU (EAC marking)

Tecfluid S.A. have subjected the series DP of flowmeters to a certification procedure according to the technical regulations of the Customs Union of the Eurasian Economic Union (EEU).



This Certificate is an official document confirming the quality of production with the standards on the territory of the Customs Union, particularly regarding safety requirements and electromagnetic compatibility.

23 ADDITIONAL INSTRUCTIONS FOR THE ATEX VERSION

This chapter only applies to equipment intended for use in explosive atmospheres.

These equipment conform with the directive 2014/34/EU (Equipment and protective systems intended for use in potentially explosive atmospheres) as indicated in the EC-type examination certificate and in its marking.

Given that this instrument is group II, it is intended for use in places likely to become endangered by explosive atmospheres, but not in mines.

For the category 1G, the equipment is intended for use in areas in which explosive atmospheres caused by mixtures of air and gases, vapours or mists are present continuously, for long periods or frequently.

For the category 1D, the equipment is intended for use in areas in which explosive atmospheres caused by inflammable dusts are present continuously, for long periods or frequently.

23.1 Non metallic parts



WARNING: POTENTIAL RISK OF ELECTROSTATIC CHARGE

The front of the housing consists of a transparent plastic window in order to let the user see the position of the pointer on the scale.

Since the danger of ignition by electrostatic discharge when rubbing this window can not be avoided, **the instrument must always be cleaned with a damp cloth.**



WARNING: RISK OF IMPACT

Because the housing base is made of aluminium, **the equipment must be installed and operated always in locations at low risk of impact.**

23.2 Connecting conductive parts to earth

When the instrument is not grounded securely through the connection process, it should be grounded through the housing screw, as shown in the figure.

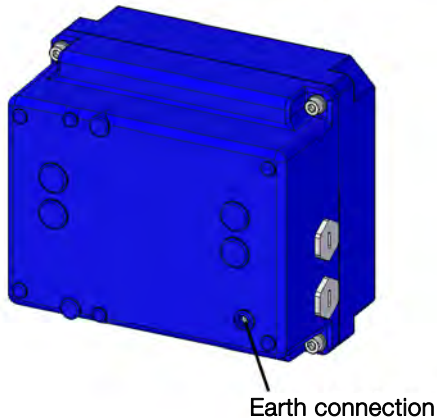

23.3 Limit switch AMD

When the equipment includes an AMD limit switch, it is certified as intrinsic safety with the following parameters:

Marking	Ex ia IIC T4	Ex ia IIC T6
Specific parameters	Ui : 16 V	Ui : 16 V
	li : 25 mA	li : 76 mA
	Pi : 64 mW	Pi : 242 mW
	Ci : 50 nF	Ci : 50 nF
	Li : 250 uH	Li : 250 uH

23.4 Limit switch AMM

When the equipment includes an AMM limit switch, can be certified as intrinsic safety. No specific electric parameters are required.

23.5 TH7 transmitters

Transmitters TH7 can be supplied with certification to be installed in potentially explosive atmospheres. They are intrinsic safety devices.

Differing from TH7 transmitters for safe zone, they do not have pulse output.

The electrical connection and the information with respect to the HART protocol is the same as in the TH7 transmitter (see sections 12 to 18).

The technical characteristics that differ from TH7 transmitters are the following:

Maximum voltage: 30 VDC

Maximum load in the 4-20 loop: 900 Ω (at 30 VDC supply voltage)

Pulse output: Not available in this version.

The rest of characteristics are the same as TH7 transmitter (see section 21.4).

The specific intrinsic safety parameters are the following:

Marking	Ex ia IIC T4	Ex ia IIC T6
Specific parameters	Ui : 30 V	Ui : 30 V
	Pi : 1,3 W	Pi : 1,3 W
	Ci : 57,3 nF	Ci : 57,3 nF

23.6 Marking

Some examples of marking are shown as follows.



The marking of the equipment shows the following characteristics:

- Manufacturer
- Model
- Serial number
- CE marking
- ATEX marking
- Certification number
- Address of the manufacturer

24 FLOW RANGES

DP65 (DN40 ... DN300)

DN	Flow scales m ³ /h water					
40	0,8-4	0,8-6	1-8	2-10	3-16	-
50	0,8-6	1-8	2-10	3-16	3-25	-
65	2-10	3-16	3-25	4-30	5-35	6-40
80	2-16	3-25	5-40	6-45	8-50	10-60
100	5-40	8-60	10-80	12-90	15-100	-
125	8-60	15-100	15-120	20-135	-	-
150	15-100	20-160	25-200	40-220	50-250	-
200	20-160	30-250	40-350	50-400	-	-
250	25-200	50-400	60-500	80-600	-	-
300	30-250	50-400	80-600	100-800	-	-

Equivalent scales for Air @ 1.013 bar abs, 20°C in Nm³/h = m³/h H₂O x 30 (approx.)

DP500 (DN250 ... DN500)

DN	Flow scales m ³ /h water		
250	25-200	50-400	60-500
300	30-250	50-400	80-600
350	40-300	60-500	100-800
400	50-400	80-600	120-1000
500	80-600	120-1000	200-1600

Equivalent scales for Air @ 1.013 bar abs, 20°C in Nm³/h = m³/h H₂O x 30 (approx.)

25 DIMENSIONS
DP65 (DN40 to DN300)

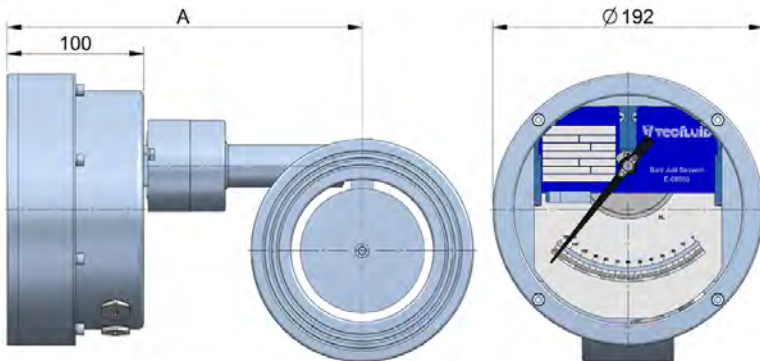
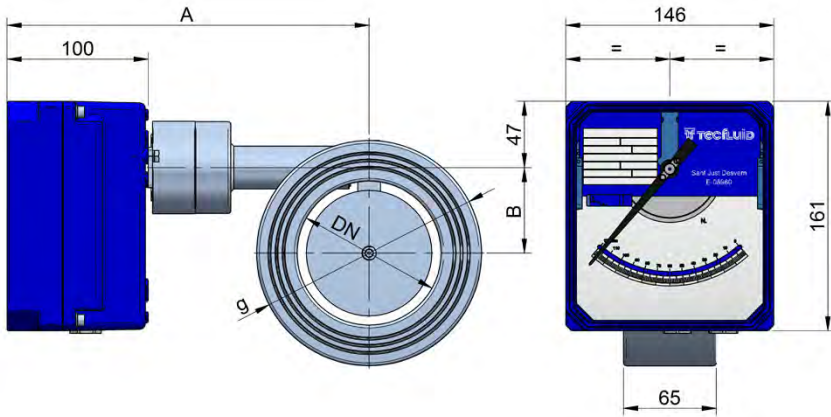

DN	g	B	A	Weight (kg)
40	88	28	250	5
50	102	33	250	6
65	122	40	250	7
80	138	50	250	8
100	158	60	250	10
125	188	70	280	12
150	212	78	280	14
200	268	90	320	20
250	320	102	350	29
300	370	115	370	35

(dimensions in mm)

DP65 with thermal separator

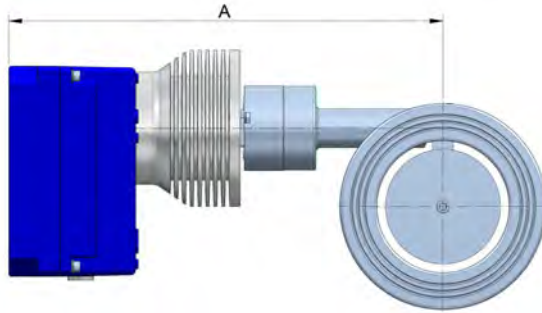

DN	A
40	325
50	325
65	325
80	325
100	325
125	355
150	355
200	395
250	425
300	443

DP500 (DN250 to DN500)

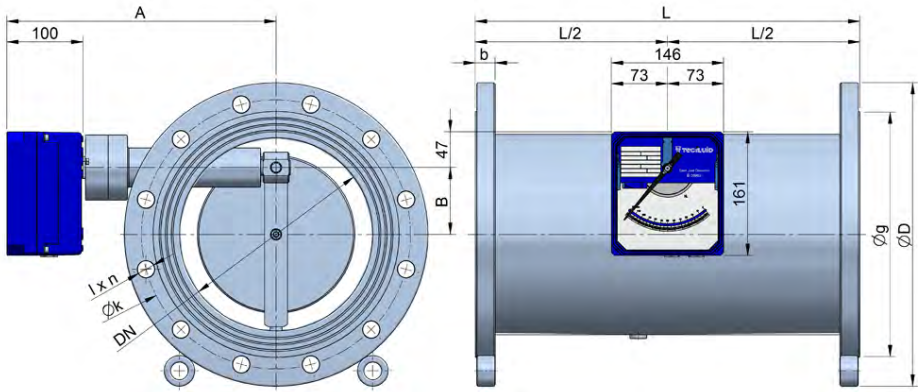

DN	L	A	B	ØD	k	g	b	l x n	Weight (kg)
250	500	330	90	395	350	320	26	23 x 12	70
300	500	330	115	445	400	370	26	23 x 12	78
350	600	350	124	505	460	430	26	23 x 16	86
400	600	350	142	565	515	482	26	27 x 16	97
500	700	430	160	670	620	585	28	27 x 20	115

(dimensions in mm)



LABORATORIO OFICIAL J. M. MADARIAGA



(1) **EC-TYPE EXAMINATION CERTIFICATE**

- (2) Equipment or protective system intended for use in potentially explosive atmospheres
Directive 94/9/EC
- (3) EC-Type Examination Certificate nr **LOM 09ATEX2087 X**
- (4) Equipment or protection system Flow and level meters
Types SC250 *, SC250H *, SM250 *, DP65 *, DP500 * y LP80 *
- (5) Applicant TECFLUID, S.A.
- (6) Address Nareis Monturiol 33
08980- Sant Just Desvern (BARCELONA)
SPAIN
- (7) This equipment or protective system and any acceptable variation thereto is specified in the schedule to this certificate and the documents therein referred to.
- (8) Laboratorio Oficial J.M. Madariaga (LOM), notified body number 0163 in accordance with Article 9 of the Directive 94/9/EC of the European Parliament of 23 March 1994, certifies that this equipment or protective system has been found to comply with the Essential Health and Safety Requirements relating to the design and construction of equipment and protective systems intended for use in potentially explosive atmospheres, given in Annex II to the Directive.
The examination and test results are recorded in confidential report nr. **LOM 09.331 XP**
- (9) Compliance with the Essential Health and Safety Requirements has been assured by compliance with:
- Standards **EN 60079-0:2006** **EN60079- 11:2007**
- (10) If the sign X is placed after the certificate number, it indicates that the equipment or protective system is subject to special conditions for safe use specified in the schedule to this certificate.
- (11) This EC-Type Examination Certificate relates only to the design and construction of this specified equipment or protective system in accordance with the Directive 94/9/EC. Further requirements of the Directive apply to the manufacture and supply of this equipment or protective system. These are not covered by this certificate.
- (12) The marking of the equipment or protective system shall include the following:

II 1 GD Ex ia IIC T*



Carlos Fernández Ramón
DIRECTOR OF THE LABORATORY

Madrid, 2009-12-03



Angel Vega Remesal
Head of the ATEX

This Certificate is a translation from the original in Spanish. The LOM liability applies only on the Spanish text

(This document may only be reproduced in its entirety and without any change) Pág. 1 / 3



UNIVERSIDAD POLITÉCNICA DE MADRID
ENSAYOS E INVESTIGACIONES DE MATERIALES Y EQUIPOS PARA ATMÓSFERAS EXPLOSIVAS Y MINERÍA
(Real Decreto 334/1992 de 3 de Abril - BOE 1992-04-29)



Alenza, 1 - 28003 MADRID • (34) 91 4421366 / 91 3367009 • (34) 91 4419933 • lom@lom.upm.es



LABORATORIO OFICIAL J. M. MADARIAGA

(A1) SCHEDULE

(A2) EC-Type Examination Certificate: LOM 09ATEX2087 X

(A3) Description of equipment or protective system

Series of flow meters and level indicator based on a section of pipe through pass a fluid, in some cases by moving a float and other moving a disk. On the tube there is an enclosure containing the flow reading system where the displacement is measured by magnetic coupling which moves a measurement dial. The movement of the needle can act on limit switch elements or to be associated to Hall effect sensor in the variants with transmitter. The limit switch elements can be either NAMUR inductive sensors type SJ3.5-N of Pepper+Fuchs which are intrinsically safe according 94/9/CE directive, or free voltage switches which are single apparatus.

Types and variants	
SC250	Flow meter with conical float
SC250H	Flow meter with conical float and spring
SM250	Flow meter with cylindrical float
DP65	Impact disc flow meter
DP500	Impact disc flow meter
LP80	Float level meter

The equipment that with two wire signal transmitter includes an electronic circuit called HALLTEC V with four variants:

TH5	4-20 mA transmitter
TH5H	4-20 mA transmitter
TH5T	4-20 mA transmitter with LCD display
TH5TH	4-20 mA transmitter HART protocol compatible and totaliser

Equipment with limit switch detectors include one or two detectors:

AMD1	One NAMUR inductive detector
AMD2	Two NAMUR inductive detectors
AMM1	One micro-switch
AMM2	One micro-switch

Type codification: *** *****

Type: SC250, SC250H, SM250, DP 65, DP500 o LP80

Transmitter variant: without transmitter, TH5, TH5H, TH5T or TH5TH

Limit switch variant: without limit switch, AMD1, AMD2, AMM1 or AMM2

Specific parameters of the type of protection and marking:

	Variants with transmitter TH5* Without encapsulation	Variants with transmitter TH5* With encapsulation	Variants only including inductive detectors		Variants only including micro-switches
Marking	Ex ia IIC T4	Ex ia IIC T6	Ex ia IIC T6	Ex ia IIC T4	Ex ia IIC T6
Specific parameters	Ui: 30 V Ci: 57,3 nF Pi: 1,3 W	Ui: 30 V Ci: 57,3 nF Pi: 1,3 W	Ui: 16 V Ii: 25 mA Pi: 64 mW Ci: 50 nF Li: 250 uH	Ui: 16 V Ii: 76 mA Pi: 242 mW Ci: 50 nF Li: 250 uH	Without parameters

When combined variants with transmitter and inductive sensors, the connection of the respective circuits should be kept separate by independent cables.

This Certificate is a translation from the original in Spanish. The LOM liability applies only on the Spanish text



RCPCR 07.3/2
Rev 0

(This document may only be reproduced in its entirety and without any change)

Pág. 2 / 3



LABORATORIO OFICIAL J. M. MADARIAGA

(A1) **SCHEDULE**

(A2) **EC-Type Examination Certificate: LOM 09ATEX2087 X**

(A4) **Test report nr. LOM 09-331 XP**

(A5) **Special conditions for safe use**

- There is electrostatic hazard due to the plastic part of the enclosure. It shall follow the manufacturer instructions.
- The wiring of the variants containing transmitter and inductive sensor must be kept separated

(A6) **Individual tests**

None

(A7) **Essential Health and Safety Requirements**

Explosion safe requirements are covered by application of the standards indicated in page 1/3 of this certificate.

(A8) **Descriptive Documents**

	Rev.	Date
- Description:	R-ET-AVIATEX 0	2009-10-06
- Drawings nr.:	268910103 0	2009-12-01
	239520061 0	2008-10-02
	239520062 0	2009-02-11
	239520063 0	2009-02-11
	239540007 0	2009-06-12
	239560022 0	2009-07-07
	228220100 0	2009-10-06
	228220101 0	2009-10-06
	228220102 0	2009-10-06
	228220103 0	2009-10-06
	228220104 0	2009-10-06
	228220105 0	2009-10-06



This Certificate is a translation from the original in Spanish. The LOM liability applies only on the Spanish text

RCPCER 07/32
Rev. 4

(This document may only be reproduced in its entirety and without any change)

Page 3 / 3



LABORATORIO OFICIAL J. M. MADARIAGA



SUPPLEMENTARY EU-TYPE EXAMINATION CERTIFICATE

- 1
2 Equipment or Protective System Intended for use in Potentially Explosive Atmospheres.
Directive 2014/34/EU
3 Supplementary EU-Type Examination Certificate Number LOM 09ATEX2087 X/1 issue 0
4 Product Flow and level meters
Types SC250 *, SC250H *, SM250 *, DP65 *, DP500 *y LP80 *
5 Manufacturer TECFLUID, S.A.
6 Address C/ Narcís Monturiol 33
08960 Sant Just Desvern (Barcelona)
SPAIN
7 This supplementary certificate extends EC -Type Examination Certificate No. LOM 09ATEX2087 X to apply to products designed and constructed in accordance with the specification set out in the Schedule of the said certificate but having any variations specified in the Schedule attached to this certificate and the documents therein referred to.
8 Laboratorio Oficial J.M. Madariaga (LOM), Notified Body number 0163 in accordance with Article 17 of Directive 2014/34/EU of the European Parliament and of the Council, dated 26 February 2014, certifies that the product, as modified by this supplementary certificate, has been found to comply with the Essential Health and Safety Requirements relating to the design and construction of products intended for use in potentially explosive atmospheres given in Annex II to the Directive. The examination and test results are recorded in confidential Report No. LOM 16.136 QP
9 In accordance with Article 41 of Directive 2014/34/EU, EC-Type Examination Certificates referring to 94/EC that were in existence prior to the date of application of 2014/34/EU (20 April 2016) may be referenced as if they were issued in accordance with Directive 2014/34/EU. Supplementary Certificates to such EC-Type Examination Certificates, and new issues of such certificates, may continue to bear the original certificate number issued prior to 20 April 2016.
10 Compliance with the Essential Health and Safety Requirements has been assured by compliance with:
Standards EN 60079-0:2012/A11:2013 EN 60079-11:2012 EN 60079-26:2015
11 The marking of the product shall include the following:

Ex II IG Ex ia IIC T+Gn (see annex)
Ex ia IIC T+G Da

Getafe,

Head of Certification Committee

RCPCR 25.17

(This document may only be reproduced in its entirety and without any change) Page 1/2



UNIVERSIDAD POLITÉCNICA DE MADRID
ENSAYOS E INVESTIGACIONES DE MATERIALES Y EQUIPOS PARA ATMÓSFERAS EXPLOSIVAS Y MINERÍA
(Real Decreto 334/1992 de 3 de Abril - BOE 1992-04-29)



Eric Kandel, I - 28906 GETAFE (MADRID) • (34) 91 4421366 • (34) 91 4419933 • lom@lom.upm.es



LABORATORIO OFICIAL J. M. MADARIAGA

13 SCHEDULE

14 Supplementary EU-Type Examination Certificate Number **LOM 09ATEX2087 X/1**

15 Description of the variation to the product

15.1 Variants integrating transmitter are modified. This transmitter is now called HALLTEC VII and replaces HALLTEC V. There are changes in components and the programming system is now based on USB only usable in safe area.

Type codification

*** **

Type: SC250, SC250H, SM250, DP 65, DP500 or LP80

Transmitter variant: without, TH7, TH7H, TH7T or TH7HT

Limit switch variant: without, AMD1, AMD2, AMM1 or AMM2

15.2 Specific parameter of the type of protection

Variant	With transmitter TH7* Not encapsulated	With transmitter TH7* Encapsulated	Only incorporating inductive sensors Type AMD from Pepperl + Fuchs GmbH	Only incorporating microswitches
Gases	Ex in IIC T4 Ga	Ex in IIC T6 Ga	Ex in IIC T6 Ga	Ex in IIC T6 Ga
Dusts	Ex in IIC T4 Da	Ex in IIC T85 °C Da	Ex in IIC T8 °C Da	Ex in IIC T85 °C Da
	Ui: 30 V Ci: 57,3 nF Pi: 1,3 W	Ui: 30 V Ci: 57,3 nF Pi: 1,3 W	The parameters indicated by the manufacturer of inductive sensors, and depending on the ambient temperature	Without parameters

15.3 Standards and marking are updated.

16 Report Number **LOM 16.230 GP**, **LOM 16.136 QP**

17 Specific conditions of use

17.1 The plastic part of the enclosure presents electrostatic hazards. It should be followed the manufacturer's instructions

17.2 The wiring of the variants containing transmitter and inductive sensor must be kept separated.

17.3 Programming via USB interface can only be done in safe area following the manufacturer's instructions

18 Essential Health and Safety Requirements

Essential Health and Safety Requirements (EHSRs) are covered by the standards listed at item 10.

19 Documents and drawings

Number	Sheets	Issue	Edition	Description
239520083	1	0	2013-11-13	Halltec VII schematics
239520083-02	1	0	2014-01-20	PCB Halltec VII
R-ET-AVIATEX	10	1	2016-10	Technical dossier
R-MI-SC250	1	1	2016-10	User's manual

(This document may only be reproduced in its entirety and without any change)

Page 2/2



Declaration of Conformity

Manufacturer:	TECFLUID S.A. Narcís Monturiol, 33 E 08960 Sant Just Desvern		
Equipment:	Series SC, DP flowmeters and LP level meters		
Models:	SC250, SC250H, SC250V, SM250, DP65, DP500, LP80		
Switches:	AMD1, AMD2, AMM1, AMM2		
Transmitters:	TH7, TH7T, TH7H, TH7TH		
Certification:	LOM 09ATEX2087X		
Group and category:		II 1G Ex ia IIC T4 Ga II 1D Ex ia IIIC T85°C Da	(transmitter TH7 not encapsulated)
		II 1G Ex ia IIC T6 Ga II 1D Ex ia IIIC T85°C Da	(transmitter TH7 encapsulated)

Standards to which conformity is declared:

Directive ATEX 2014/34/EU

EN60079-0:2009	Equipment. General requirements
EN6009-11:2012	Equipment protection by intrinsic safety "i"
EN60079-26:2007	Equipment with equipment protection level (EPL) Ga

Updates of the standards regarding those referred to the EC-TYPE examination certificate do not affect the scope of this declaration of conformity

For production, Tecfluid S.A. complies with the annex IV of the directive 2014/34/EU, having the notification for production quality assurance n. LOM 02ATEX9033, of the notified body with identification number 0163 (Laboratorio Oficial J.M. Madariaga)

I, the undersigned, declare that the equipment stated above conforms with the essential requirements of the Directives of the European Parliament and the Council on the approximation of the laws of Member States concerning equipment and protective systems intended for use in potentially explosive atmospheres.

In Sant Just Desvern
Date: December 15, 2016

Esteve Cusidó (R&D manager)



Declaration of Conformity

Manufacturer: TECFLUID S.A.
Narcís Monturiol, 33
E 08960 Sant Just Desvern

Equipment: Flowmeters and level meters

Models: Series SC, DP, LP

Declaration:

Having reviewed the essential health and safety requirements related to the design and construction of equipment and protective systems intended for use in potentially explosive atmospheres, Tecfluid S.A. consider that this device is outside the scope of the Directive 2014/34/EU, given that it does not content any potential ignition sources. Therefore it does not require certification by a notified body or marking in conformity with the ATEX Directive.

Special emphasis has been done in the compliance of EN 13463:2001 standard.

13463-1 5.1

Instructions for use of the equipment include the terms of service.

13463-1 5.2

Ignition hazard assessment.

Potential ignition source		Description of the measure(s) applied
Normal operation	Expected malfunction	
Hot surfaces		The equipment itself does not generate any increase of heat, the maximum temperature will depend on the operating conditions (process temperature)
Ingress of dust inside the enclosure		The equipment has an IP65 ingress protection to avoid ingress of dust into the enclosure
Static electricity		A warning label indicating risk of static electricity is placed
Impact of moving parts		Sparks cannot be generated since material is aluminium
Bearings		The bearings cannot generate an ignition
Mechanical resistance		Impact test is performed

13463-1 6.1

Maximum surface temperature. The devices themselves do not generate any heat.

13463-1 7.2

Classification of non-metallic parts.

There is a non-metallic part in the instrument. It is the front window of the cover. It is made of a transparent plastic (polycarbonate resin, whose trademark is LEXAN® 143R) that allows viewing the needle position on the scale.

13463-1 7.3

Thermal endurance.

The temperature index of the equipment is 130 ° C.

13463-1 7.4

When the metal enclosure is made of aluminium, it is coated with an insulating paint whose thickness is always less than 2 mm.

Since the risk of ignition by electrostatic discharge when rubbing the polycarbonate front window cannot be avoided, the instruments include a warning label with the safety measures to be applied in service.

The same case applies to the entire enclosure when it is made of polypropylene.

13463-1.8

Lightweight materials.

The index of the metal magnesium in the equipment of aluminium enclosure is around 0.2%, well below the established limit of 7.5%.

13463-1 11

Connection facilities for earthing conducting parts.

The instruments have a safe earth connection for cases where this earth connection by means of the process connection cannot be ensured.

In Sant Just Desvern
Date: November 5, 2015



Esteve Cusidó (R&D manager)

WARRANTY

Tecfluid S.A. guarantee all the products for a period of 24 months from their sale, against all faulty materials, manufacturing or performance. This warranty does not cover failures which might be imputed to misuse, use in an application different to that specified in the order, the result of service or modification carried out by personnel not authorized by Tecfluid S.A., wrong handling or accident.

This warranty is limited to cover the replacement or repair of the defective parts which have not damaged due to misuse, being excluded all responsibility due to any other damage or the effects of wear caused by the normal use of the devices.

Any consignment of devices for repair must observe a procedure which can be consulted in the website www.tecfluid.com, "After-Sales" section.

All materials sent to our factory must be correctly packaged, clean and completely exempt of any liquid, grease or toxic substances.

The devices sent for repair must enclose the corresponding form, which can be filled in via website from the same "After-Sales" section.

Warranty for repaired or replaced components applies 6 months from repair or replacement date. Anyway, the warranty period will last at least until the initial supply warranty period is over.

TRANSPORTATION

All consignments from the Buyer to the Seller's installations for their credit, repair or replacement must always be done at freight cost paid unless previous agreement.

The Seller will not accept any responsibility for possible damages caused on the devices during transportation.



Tecfluid S.A.

Narcís Monturiol 33
08960 Sant Just Desvern
Barcelona

Tel: +34 93 372 45 11

Fax: +34 93 473 44 49

tecfluid@tecfluid.com

www.tecfluid.com

Quality Management System ISO 9001 certified by



Pressure Equipment Directive 2014/68/UE certified by



ATEX European Directive 2014/34/EU certified by



HART® is a registered trademark of Fielcomm Group

The technical data described in this manual is subject to modification without notification if the technical innovations in the manufacturing processes so require.