



Instructions manual



PREFACE

Thank you for choosing the flowmeter series TM from Tecfluid S.A.

This instruction manual allows the installation and operation of the turbine flowmeter series TM. It is recommended to read it before using the equipment.

WARNINGS

- This document shall not be copied or disclosed in whole or in any part by any means, without the written permission of Tecfluid S.A.
- Tecfluid S.A. reserves the right to make changes as deemed necessary at any time and without notice, in order to improve the quality and safety, with no obligation to update this manual.
- Make sure this manual goes to the end user.
- Keep this manual in a place where you can find it when you need it.
- In case of loss, ask for a new manual or download it directly from our website www.tecfluid.com Downloads section.
- Any deviation from the procedures described in this instruction manual, may cause user safety risks, damage of the unit or cause errors in the equipment performance.
- Do not modify the equipment without permission. Tecfluid S.A. is not responsible for any problems caused by a change not allowed. If you need to modify the equipment for any reason, please contact us in advance.

TABLE OF CONTENTS

1	WORKING PRINCIPLE	4
2	RECEPTION	4
2.1	Unpacking	4
2.2	Storage temperature	4
3	INSTALLATION	4
3.1	Filter	5
3.2	Open discharge	5
3.3	Position	5
3.4	Straight pipe sections	5
3.5	Valves	6
3.6	Pumps	6
3.7	Electrical connection	7
4	MAINTENANCE	8
4.1	Disassembly	9
4.2	Cleaning	9
4.3	Mounting	9
4.4	Pickup	9
4.5	Replacing the pickup	9
5	PART LIST	10
6	TECHNICAL DATA	11
7	DIMENSIONS AND WEIGHTS	12
8	K FACTOR (PULSES / LITRE)	14
9	ADDITIONAL INSTRUCTIONS FOR THE ATEX VERSION	14
9.1	Intrinsic safety	14
9.2	Flameproof enclosure	14
9.2.1	Facilities connecting conductive parts to earth	15
9.2.2	Maintenance	15
9.2.3	Technical data for the ATEX version	15
9.2.4	Marking	16
9.2.5	Dimensions and weights	17
10	TROUBLESHOOTING	19

1 WORKING PRINCIPLE

One helical rotor turns freely inside a cylindrical tube.

The working liquid pushes the rotor blades, making them turn at a flow speed which is proportional to the flow rate.

A pick-up coil mounted externally receives the propeller turns and generates an electrical signal which, once treated by the different electronic converters, can provide flow rate indication, total or partial volume, digital and analog outputs.

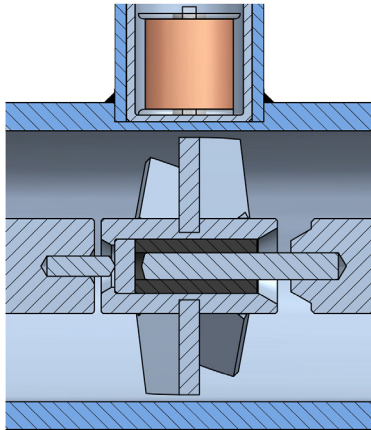

2 RECEPTION

The TM turbine flowmeters are supplied individually packed for protection during transport and storage including their corresponding instructions manual, for their installation and use.

All the flowmeters have been verified in our flow rigs, obtaining the K factor for each device.

2.1 Unpacking

Unpack the instrument carefully, removing any remains of the packing from the inside of the sensor.

2.2 Storage temperature

-20°C ... +60°C

3 INSTALLATION

The installation must be made in a point that ensures that the pipe is completely full of liquid.

Highest points in the installation as well as downwards pipes must be avoided, since air pockets or vacuums might occur.

In installations where air can be present, a degasser must be installed before the flowmeter.

Partially full pipe can involve important measurement errors.

3.1 Filter

A filter should be installed before the turbine to guarantee correct working and avoid expensive damage. The filter should have a mesh size of maximum of 200 μm to avoid larger particles that may block the turbine propeller .

3.2 Open discharge

When the flow measurement is to be made before an open discharge, it is necessary to install the flowmeter in a section of pipe with a trap which avoids the presence of air inside the meter.

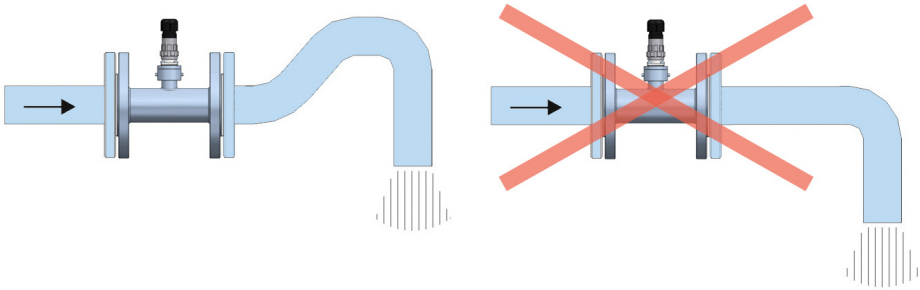

3.3 Position

The installation and position of the turbine flowmeter can be either vertical, horizontal or inclined. Make sure that the flow direction is as marked by the arrow on the turbine body.

3.4 Straight pipe sections

To obtain good readings, turbulences must be avoided. For this it is necessary to have straight sections of pipe upstream and downstream of the turbine. The straight pipe sections must be of the same internal diameter as the turbine and the minimum lengths must be the following:

Upstream	10 DN
Downstream	7 DN

These sections must be free of deviations or disturbing elements (valves etc.).

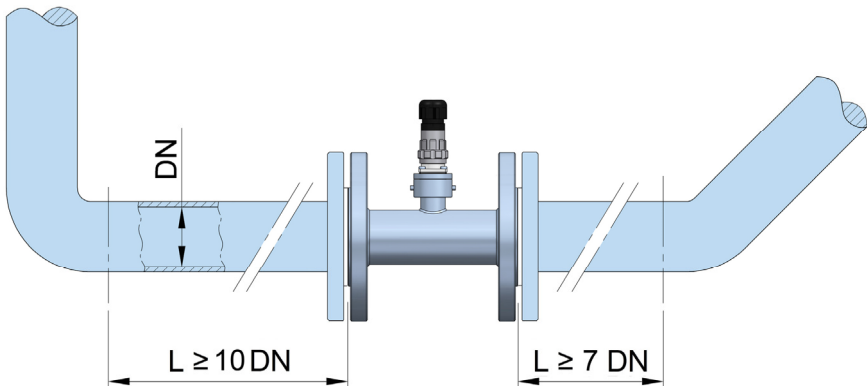

These distances can be reduced by installing a flow straightener upstream of the turbine at a distance equivalent to 5 DN.

3.5 Valves

Regulating or shut-off valves must always be installed after the turbine, in order to assure that pipe is full of liquid.

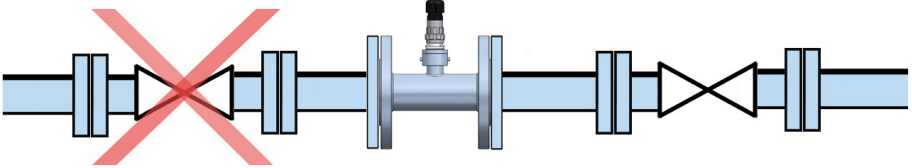

3.6 Pumps

Pumps must always be installed before the turbine in order to avoid cavitation.

This way the presence of air pockets in the flowmeter is avoided, which could cause unbalance of the propeller which could damage the turbine.

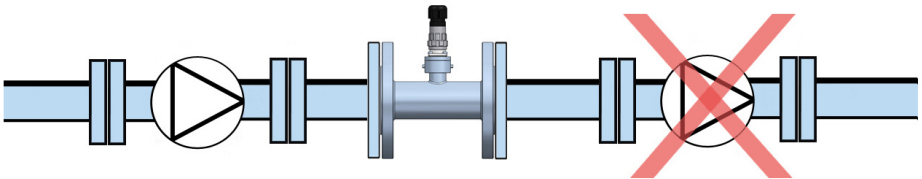

Note: To avoid cavitation the pressure at the outlet of the turbine should be higher than twice the pressure loss of the turbine (see table N° 2) plus 1.25 times the vapour pressure of the liquid or its most volatile component.

3.7 Electrical connection



It is important to keep the connecting cable between the flowmeter and the auxiliary electronics away from mains or power supply cables, in order to avoid interferences. In any case, those should be separated at least 5 cm.

The turbine flowmeter has an IP65 connector fastened to the counter by means of 4 screws. The connector consists of 3 parts joined by threaded nuts. (See figure).

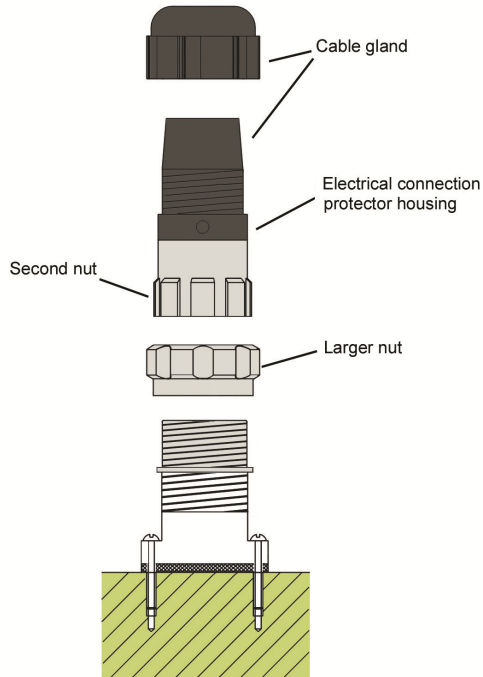

Loosening the larger nut in the middle of the connector allows us to withdraw the half where the cable will be later soldered.

The other half of the connector is fixed to the counter and should not be removed, except when servicing the detector (See point 4.5 of the MAINTENANCE section).

The removable part of the connector consists of the cable gland at the top and the electrical connection protector housing.

Before starting the installation, check that the cable gland is the right size for the cable to be used. This will guarantee the instrument will stay watertight. The cable gland used is for cables with outside diameters between 6 mm and 10 mm.

The electrical connection protector housing is dismounted by loosening the second nut.

When this is removed, the three connector terminals are visible.

The terminals are numbered 1 to 3 and the connection is as follows:

- N° 1: Ground
- N° 2: Coil
- N° 3: Coil

Before soldering the connections, unscrew the cable gland and feed it, together with the electrical connection protector housing, over the cable.

The joint between the cable and the connector should always be soldered, and should be tidy and without short circuits between terminals.

Peel the outside insulation to free the inner cables. It is recommended to tin the ends of the wires to avoid loose ends.

Once the connections have been made, the housing should be mounted screwing it on and then the cable gland should be tightened to avoid entry of any liquid or humidity.

Once assembled the half of the connector, the mounting in the base has only one position defined by the keyway between the two parts.

Check that the rubber seal is in its position inside the connector base. If this is the case, introduce the connector half in the base, positioning by the keyway, and screw on the nut until the end of the thread is reached.

4 MAINTENANCE

The simple construction of the TM turbine results in a long life in normal working conditions.

The life of the parts depends mainly on the abrasive characteristics of the product to be measured and the maximum flow rate.

The combination of these two factors make it difficult to estimate the life of the components in good working conditions.

If the maximum flow rates given for each DN in the following table are exceeded the life is considerably reduced.

Flow ranges

DN	Minimum flow rate (m ³ /h)	Maximum flow rate (m ³ /h)	Pressure drop (mm H ₂ O) at maximum flow rate	Maximum intermittent flow rate (m ³ /h)
15	0,3	3	7500	5
20	0,6	6,8	7500	8
25	0,9	13,5	7000	16
40	1,9	30	5600	40
50	5	50	2800	60
65	9	90	2400	115
80	15	150	3100	180
100	28	280	4500	340
125	45	450	2400	560
150	65	650	2500	820

The only parts that may need periodical maintenance are the propeller shaft and bearing. The rest of the pieces will only need maintenance when there is chemical attack or abrasion by the fluid being measured.

It has been confirmed that the life of these parts under normal working conditions is longer than 20.000 hours.

4.1 Disassembly

The numbering of the different elements corresponds to the table and drawing in the "Parts List" section on Page 10.

Inside the metering tube (1) are located the deflectors (2) (9) and the propeller (6). The inlet deflector (2) has a stop (4) inserted and the outlet deflector (9) has a shaft (8).

The deflectors are dismounted by withdrawing the circlips (3) which hold them in. They are mounted at about 5 mm from the ends of the metering tube and are easily removed with a screwdriver.

Remove the circlip of the outlet deflector. Place the turbine in a horizontal position and withdraw the deflector. The propeller assembly will come out together with the deflector.

Remove the circlip at the other end and withdraw the inlet deflector.

4.2 Cleaning

The propeller assembly contains the bearing (7) and the tungsten disk (5). These must not be disassembled.

To clean the inside of the bearing use a cloth or soft paper wrapped around a fine shaft; do not use abrasive elements. Cleaning liquids can be used to help remove dirt or grease.

To clean the propeller shaft (6) clean with a cloth soaked in alcohol, soapy water or solvent. The propeller should rotate freely on the shaft but should not be loose. It should not have a play of more than 1 part in 50 of the shaft diameter.

The rest of the pieces can be cleaned with the same products.

4.3 Mounting

Before starting to mount the turbine make sure that all the pieces are completely dry, with this we can prevent the propeller shaft from seizing.

The turbine should be mounted as follows:

Slide the inlet deflector (2) in its place (use the flow direction arrow to determine the correct end) and fix it with a circlip (3).

Fit the propeller assembly on the shaft (8) of the outlet deflector (9).

With the metering tube (1) in a horizontal plane introduce the outlet deflector assembly and fix it with a circlip (3).

Check that the assembly is not loosen and that the two circlips are correctly seated. There should only be about 0,5 mm axial play of the propeller assembly on its shaft.

The turbine is ready for installation and operation.

4.4 Pickup

To determine if the pickup group is working properly, the impedence between terminals 2 and 3 of the base connector (14) have to be measured with a multimeter. The value should be between 1500 and 2500 Ohm.

4.5 Replacing the pickup

The female plug (13), as indicated in the Installation section, can be removed from the base (14) by unscrewing the larger nut. The male connector base is fixed to the coil support (11).

Unscrew the female connector in order to separate the cable and after that unscrew the pickup group from the turbine metering tube (1).

To insert a new pickup group, follow the inverse process.

5 PART LIST

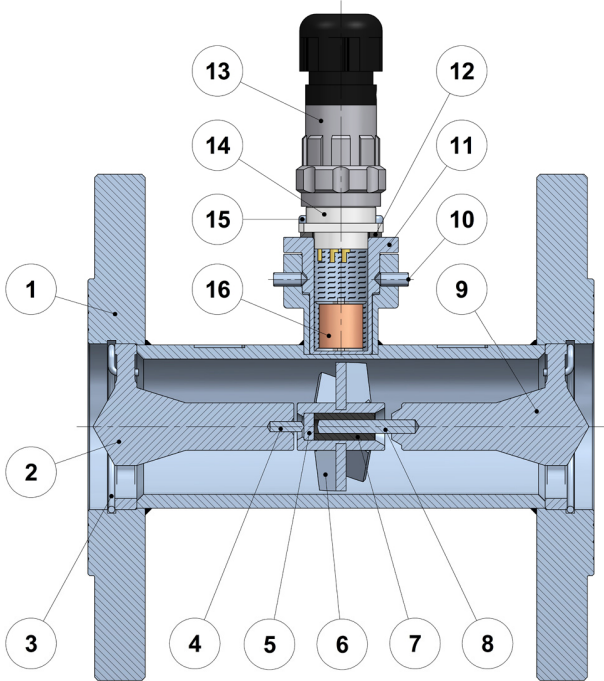

N°	Description	Material
1	Measuring tube	EN 1.4404
2	Inlet deflector	EN 1.4404
3	Circlip	EN 1.4401
4	Stop	Tungsten
5	Disc	Tungsten
6	Propeller	EN 1.4016
7	Bearing	Graphite
8	Shaft	Tungsten
9	Outlet deflector	EN 1.4404
10	Screw DIN 913 M4 x 8	EN 1.4301
11	Pickup group	EN 1.4305
12	Gasket	NBR
13	Female connector	Aluminium alloy
14	Male connector	Aluminium alloy
15	Screw DIN 7985 M3 x 8	EN 1.4301
16	Pickup	—

6 TECHNICAL DATA

Accuracy

± 0.5% measured value

Repeatability

± 0.1% measured value

Temperature

Process temperature:

-50 °C ... +170 °C

Ambient temperature:

-20 °C ... +60 °C

Connections

EN 1092-1 flanges. Other flange standards.

BSP or NPT threaded connections

Sanitary couplings according to ISO 2852, SMS 1145, DIN 11851, TRI-CLAMP®

Materials

Body: EN 1.4404 (AISI 316L)

Propeller: EN 1.4016 (AISI 430)

Working pressure

DN15 ... DN50: PN40

DN65 ... DN150: PN16

Others on request

Electrical connection

By means of IP65 connector.

Signal amplitude

> 15 mV, proportional to flow rate

Recommended cable

Shielded bifilar up to 30 m length.

NOTE: For distances up to 100 m the APTM44 amplifier shall be used.

Conforms with the Pressure Equipment Directive 97/23/EC.



This equipment is considered as being a pressure accessory and **NOT** a safety accessory as defined in the 97/23/CE directive, Article 1, paragraph 2.1.3.

Associated electronics

CIP / CIP II: Battery powered volumetric counter.

CP ... CH420: 2-wire analog transmitter with flow rate and volume indication.
HART protocol optional.

MC01: Flow rate and volume indicator with relay output for batching.

MT02: Volume counter with relay output for batching.

DFD2: Frequency divider.

CI420: Analog transmitter.

APTM44: Pulse converter for the pickup signal.

7 DIMENSIONS AND WEIGHTS

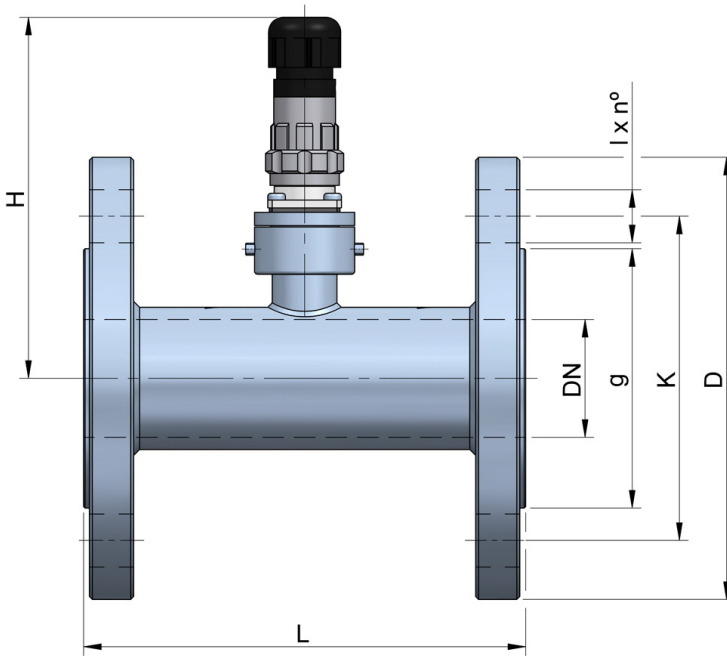

DN	PN (flanges)	D	K	g	l x n°	L	H (max)	Weight (kg)
15	40	95	65	45	14 x 4	100	115	2,0
20	40	105	75	58	14 x 4	100	115	2,5
25	40	115	85	68	14 x 4	130	120	3,5
40	40	150	110	88	18 x 4	150	125	5,0
50	40	165	125	102	18 x 4	150	130	7,0
65	16	185	145	122	18 x 8 *	160	140	10,0
80	16	200	160	138	18 x 8	160	145	12,0
100	16	220	180	158	18 x 8	250	155	17,0
125	16	250	210	188	18 x 8	280	170	21,0
150	16	285	240	212	22 x 8	300	180	27,0

* 18 x 4 in case of DIN 2501 flanges

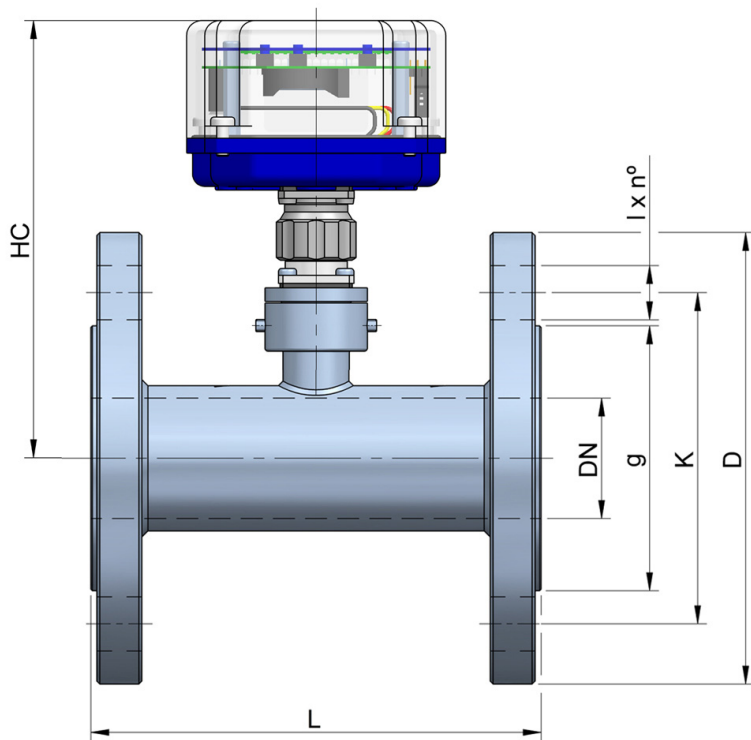

DN	PN (flanges)	D	K	g	l x n°	L	HC (max)	Weight (kg)
15	40	95	65	45	14 x 4	100	140	2,2
20	40	105	75	58	14 x 4	100	140	2,7
25	40	115	85	68	14 x 4	130	145	3,7
40	40	150	110	88	18 x 4	150	150	5,2
50	40	165	125	102	18 x 4	150	155	7,2
65	16	185	145	122	18 x 8 *	160	165	10,2
80	16	200	160	138	18 x 8	160	170	12,2
100	16	220	180	158	18 x 8	250	180	17,2
125	16	250	210	188	18 x 8	280	195	21,2
150	16	285	240	212	22 x 8	300	205	27,2

* 18 x 4 in case of DIN 2501 flanges

8 K FACTOR (PULSES / LITRE)

DN	Pulses / litre ± 10%	cm ³ / pulse ± 10%
15	730	1,28
20	500	2
25	220	4,5
40	60	16
50	20	50
65	10	100
80	5	200
100	3	333
125	1,5	666
150	0,8	1250

Measured values for water at 20 °C

9 ADDITIONAL INSTRUCTIONS FOR THE ATEX VERSION

This chapter only applies to equipment intended for use in explosive atmospheres.

9.1 Intrinsic safety

The flowmeters of series TM, when include just the pickup sensor and the connector, can be considered simple apparatus as defined in the EN 60079-11 standard. In these cases it can be installed in hazardous areas provided that they are connected to a zener barrier or to an intrinsic safety isolator. Please consult factory for the recommended models.

9.2 Flameproof enclosure

These equipment conform with the directive 94/9/CE (Equipment and protective systems intended for use in potentially explosive atmospheres) as indicated in the EC-type examination certificate LOM 14ATEX2008 X and its marking.

Given that this instrument belong to group II, it is intended for use in places likely to become endangered by explosive atmospheres, but not in mines.

The category is 2GD, that is, it is intended for use in areas in which explosive atmospheres caused by mixtures of air and gases, vapours, mists or air/dust mixtures are likely to occur.

9.2.1 Facilities connecting conductive parts to earth

When the instrument is not grounded securely through the connection process, it should be grounded through the housing screw, as shown in the figure.

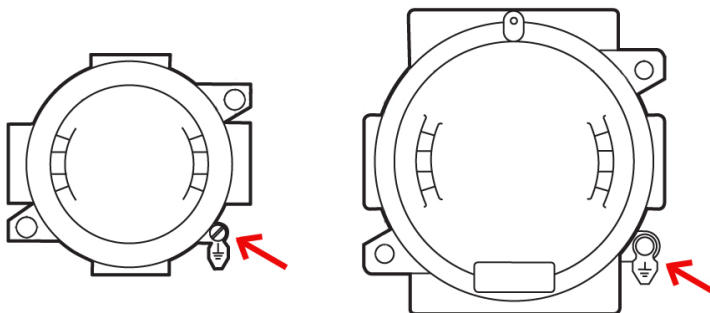

9.2.2 Maintenance



NOTE: When the flameproof enclosure contains an electronics model CIP or CIP II, it **should never be opened in presence of explosive atmosphere.**

For the rest of models, before any maintenance that involves opening the flameproof enclosure, **make sure there is no voltage in any of internal components.**

There is no special maintenance for the ATEX version.

9.2.3 Technical data for the ATEX version

Temperature

Ambient temperature: -20 ... +60 °C

Electrical connection

Inside the flameproof enclosure.

Recommended cable

The standard thread supplied for the cable gland connection is 3/4" NPT.

ATEX cable glands for non-armoured or armoured cables can be placed.

The outer diameter of the cables that fits the 3/4" NPT cable glands is between 6 and 21 mm.

Associated electronics

CIP / CIP II: Battery powered volumetric counter.

CP ... CH420: 2-wire analog transmitter with flow rate and volume indication.
HART protocol optional.

Conforms to 94/9/EC Directive (equipment and protective systems intended for use in potentially explosive atmospheres).

The rest of characteristics are the same as in the point 6.



9.2.4 Marking

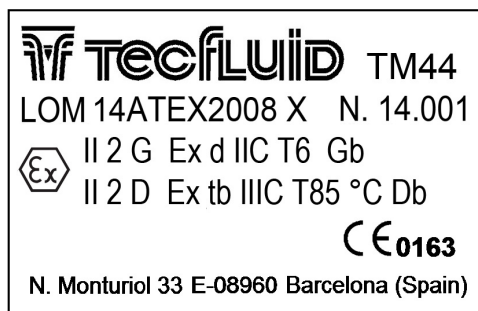

The marking of the equipment shows the following characteristics:

- Manufacturer
- Model
- Serial number (year of construction and number)
- CE marking
- ATEX marking
- Certification number
- Address of the manufacturer

9.2.5 Dimensions and weights

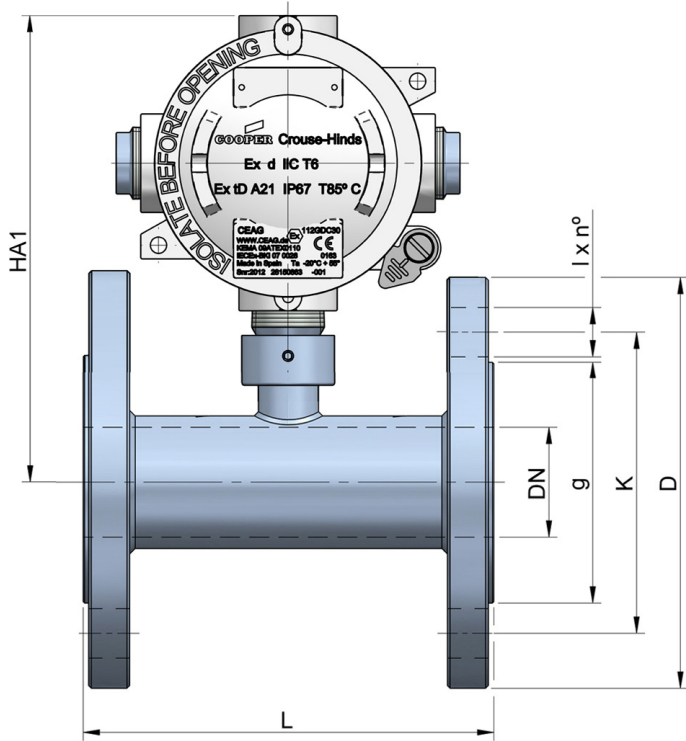

DN	PN (flanges)	D	K	g	l x n°	L	HA1 (max)	Weight (kg)
15	40	95	65	45	14 x 4	100	160	2,5
20	40	105	75	58	14 x 4	100	160	3,0
25	40	115	85	68	14 x 4	130	165	4,0
40	40	150	110	88	18 x 4	150	170	5,5
50	40	165	125	102	18 x 4	150	175	7,5
65	16	185	145	122	18 x 8 *	160	185	10,5
80	16	200	160	138	18 x 8	160	190	12,5
100	16	220	180	158	18 x 8	250	200	17,5
125	16	250	210	188	18 x 8	280	215	21,5
150	16	285	240	212	22 x 8	300	225	27,5

* 18 x 4 in case of DIN 2501 flanges

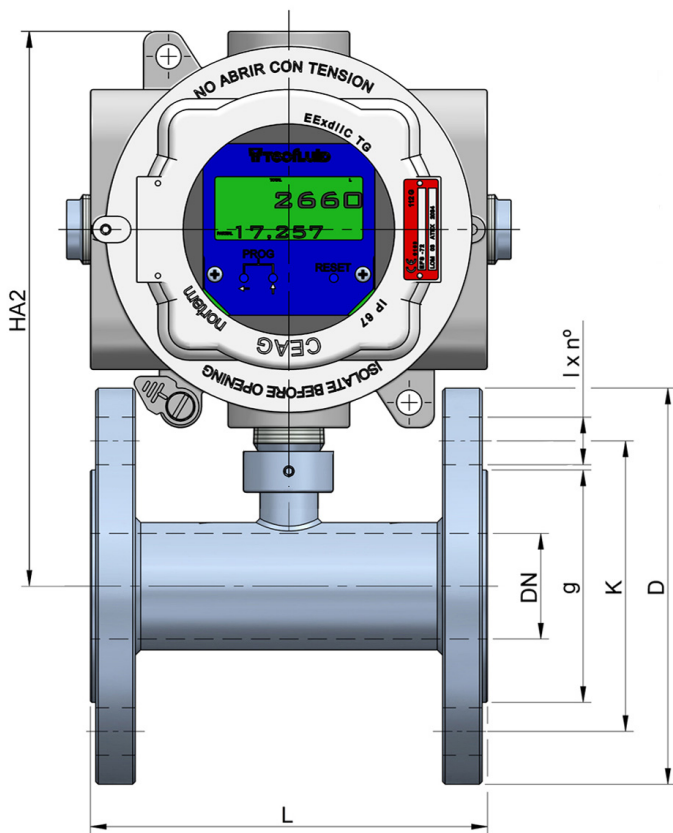

DN	PN (flanges)	D	K	g	I x n°	L	HA2 (max)	Weight (kg)
15	40	95	65	45	14 x 4	100	205	3,5
20	40	105	75	58	14 x 4	100	205	4,0
25	40	115	85	68	14 x 4	130	210	5,0
40	40	150	110	88	18 x 4	150	215	6,5
50	40	165	125	102	18 x 4	150	220	8,5
65	16	185	145	122	18 x 8 *	160	230	11,5
80	16	200	160	138	18 x 8	160	235	13,5
100	16	220	180	158	18 x 8	250	245	18,5
125	16	250	210	188	18 x 8	280	260	22,5
150	16	285	240	212	22 x 8	300	270	28,5

* 18 x 4 in case of DIN 2501 flanges

10 TROUBLESHOOTING

Problem	Probable cause	Solution
The associated electronics does not totalize	Blockage or friction of the turbine propeller by particles	Install a filter according to specification (maximum mesh size = 200 μm).
	Damaged pickup	Change the pickup
	Disconnected cables between the turbine and the associated electronics	Check the cable connection
The associated electronics totalize less than the actual volume	Blockage or friction of the turbine propeller by particles	Install a filter according to specification (maximum mesh = 200 μm).
The associated electronics totalizes more than the actual volume	Presence of air pockets	Control the minimum tank level. Provide an air degasser upstream of the turbine if air intakes can be expected.
	Excessive emptying of storage tanks	
The flow rate indicated by the associated equipment is unstable	The pipe is not completely full	Make sure that the pipe is completely full, for example, installing the flowmeter in a vertical pipe with upwards flow
	Straight pipe sections before and after the flowmeter have not been kept	Check that there are enough straight pipe sections as indicated in point 3.4.

WARRANTY

Tecfluid S.A. guarantees all the products for a period of 24 months from their sale, against all faulty materials, manufacturing or performance. This warranty does not cover failures which might be imputed to misuse, use in an application different to that specified in the order, the result of service or modification carried out by personnel not authorized by Tecfluid S.A., wrong handling or accident.

This warranty is limited to cover the replacement or repair of the defective parts which have not damaged due to misuse, being excluded all responsibility due to any other damage or the effects of wear caused by the normal use of the devices.

Any consignment of devices for repair must observe a procedure which can be consulted in the website www.tecfluid.com, "After-Sales" section.

All materials sent to our factory must be correctly packaged, clean and completely exempt of any liquid, grease or toxic substances.

The devices sent for repair must enclose the corresponding form, which can be filled in via website from the same "After-Sales" section.

Warranty for repaired or replaced components applies 6 months from repair or replacement date. Anyway, the warranty period will last at least until the initial supply warranty period is over.

TRANSPORTATION

All consignments from the Buyer to the Seller's installations for their credit, repair or replacement must always be done at freight cost paid unless previous agreement.

The Seller will not accept any responsibility for possible damages caused on the devices during transportation.



Tecfluid S.A.

Narcís Monturiol 33
08960 Sant Just Desvern
Barcelona
Tel: +34 93 372 45 11
Fax: +34 93 473 44 49
tecfluid@tecfluid.com
www.tecfluid.com

Quality Management System ISO 9001 certified by **Applus[®]**

Pressure Equipment Directive 97/23/CE certified by **Lloyd's Register**

ATEX European Directive 94/9/CE certified by



HART[®] is a registered trademark of HART Communication Foundation

The technical data described in this manual is subject to modification without notification if the technical innovations in the manufacturing processes so require.