



Instructions manual



PREFACE

Thank you for choosing the MT03L converter from MT03 series of Tecfluid S.A.

This instruction manual allows the installation, configuration and programming of the electronic converter MT03L. It is recommended to read it before using the equipment.

WARNINGS

- This document shall not be copied or disclosed in whole or in any part by any means, without the written permission of Tecfluid S.A.
- Tecfluid S.A. reserves the right to make changes as deemed necessary at any time and without notice, in order to improve the quality and safety, with no obligation to update this manual.
- Make sure this manual goes to the end user.
- Keep this manual in a place where you can find it when you need it.
- In case of loss, ask for a new manual or download it directly from our website www.tecfluid.com Downloads section.
- Any deviation from the procedures described in this instruction manual, may cause user safety risks, damage of the unit or cause errors in the equipment performance.
- Do not modify the equipment without permission. Tecfluid S.A. is not responsible for any problems caused by a change not allowed. If you need to modify the equipment for any reason, please contact us in advance.

TABLE OF CONTENTS

1	INTRODUCTION	5
2	RECEPTION	5
2.1	Storage temperature	5
3	INSTALLATION	5
3.1	Location	5
3.2	Electrical connection	6
3.2.1	Power supply wiring	6
3.2.2	Resistance input wiring	7
3.2.3	Current input wiring	7
3.2.4	Analog output wiring	8
3.2.5	Relay output wiring	9
4	OPERATION	11
5	MAIN MENU	12
5.1	Passwords to access the menus	12
6	INSTALLATION PARAMETERS	14
6.1	Language	15
6.2	Input	15
6.3	Limits	15
6.3.1	Capture	15
6.3.2	Distance adjustment	16
6.4	Diagnosis	16
7	PROGRAMMING PARAMETERS	17
7.1	Language	18
7.2	Units	18
7.3	Decimals	18
7.4	Damping	19
7.5	Outputs	19
7.5.1	Relay 1 and relay 2	19
7.5.1.1	Alarm	19
7.5.1.2	No action	20
7.5.2	Analog output	20
7.5.2.1	Programming of the 4-20 mA output	21
7.5.2.2	Current calibration for 4 and 20 mA	21

8	SERIAL NUMBER	21
9	SOFTWARE VERSION	21
10	BRIGHTNESS	22
11	WORKING SCREEN	22
12	MAINTENANCE	22
	12.1 Fuse	22
13	ASSOCIATED SOFTWARE WINSMETER MT03	22
	13.1 USB cable connection and drivers installation	22
	13.2 Port connection	24
	13.3 Access to installation and programming	24
	13.4 Visualization	26
	13.5 Firmware updates	27
14	TECHNICAL CHARACTERISTICS	29
15	DIMENSIONS	30
16	TROUBLESHOOTING	31

1 INTRODUCTION

MT03L converters are indicators for level measurement applications.

The electronic circuit is based on the most advanced technology in digital signal processing, in order to obtain accurate and reliable measurements.

The equipment provides the following features (depending on the model):

- Graphic display with intuitive menus.
- Resistance input compatible with level transmitters series LE and transmitters LTE from series LT, as well as with most of the level transmitters based in variation of resistance.
- Analog input 4-20 mA.
- Level indication.
- Current output (4-20 mA) proportional to the level and user programmable.
- Relay outputs user programmable as level alarm..

2 RECEPTION

Converters of series MT03 are supplied conveniently packaged for transportation together with their instruction manual for installation and operation.

All devices have been verified in our facilities.

2.1 Storage temperature

-20°C +60°C

3 INSTALLATION

3.1 Location

The MT03L converter is housed in a box according to IEC 61554 standard. Its size is 96x96 mm and is intended to be mounted on a panel of a cabinet with a square hole of 90 x 90 mm +0.5 mm / -0 mm. The cabinet should have a minimum depth of 90 mm behind the panel.

To place it into the cabinet, slide it through the front panel to the bottom as shown in the following figure. Then screw the clamping arms until exert pressure on the panel.

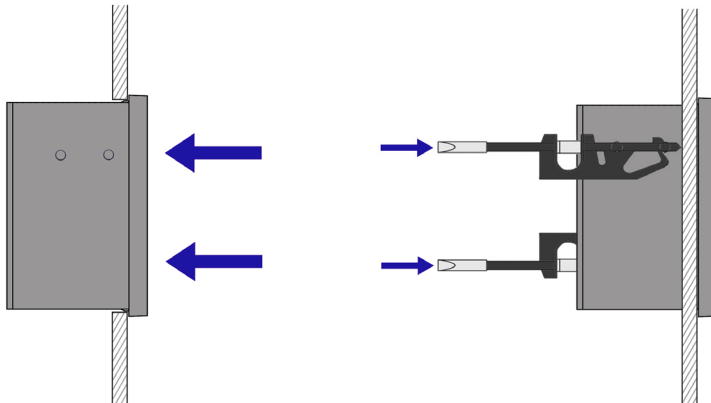

3.2 Electrical connection

The connection of the equipment is via plug-in connectors, polarized to avoid mistakes when plugged in. The connectors have screw terminals, as per VDE standards, to accept cables with section of 1.5 mm².

The pictures of the connections in this manual are always looking at the equipment from the back.

To help in the wiring of the equipment, the description of the terminals is marked on a label in the rear side of the device.

For the electrical installation it is recommended to use multiple conductor cables with individual cable sections in the order of 0.25 to 0.5 mm² in order to make it easier to connect. It is better to maintain the cables with mains voltage (power supply) separated from the cables with low level signals (4-20 mA, etc.).

To connect the cables, peel the outside insulation to free the inner cables. It is recommended to put a terminal at the ends of the wires to avoid loose ends.

Then, screw the wires into the corresponding positions in the female aerial connector. Finally, place each connector with its corresponding male connector on the rear side of the converter.



IMPORTANT NOTE: In order to comply with the electrical safety requirements as per EN-61010-1 (IEC 1010-1), the installation of the equipment must take into account the following:

- The equipment must be installed in the front panel of an electrical mounting cabinet, leaving only the front of the equipment accessible to the operator.
- In case of AC power supply, a mains switch must be provided to disconnect the equipment. This switch must be marked as the disconnecting device for the equipment and be within easy reach of the operator.
- The housing must not be opened when the instrument has mains supply connected.



IMPORTANT NOTE: To ensure smooth operation of the equipment, it is recommended to make the connection paying attention to the following points:

- For the output signals, use shielded cable when possible.
- Keep the cables away from strong sources of noise.

3.2.1 Power supply wiring

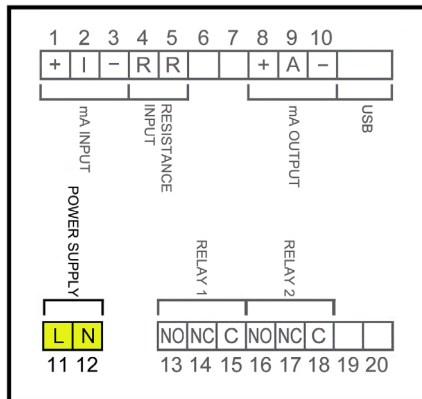



Before starting the wiring of the instrument, check that the supply voltage available is the same as marked on the label of the converter.

<u>Terminal</u>	<u>Power supply AC</u>	<u>Power supply DC</u>
11	Phase	DC
12	Neutral	DC

In case of DC power supply, the equipment is provided by a diode bridge that allows connecting it regardless of the polarity.

3.2.2 Resistance input wiring

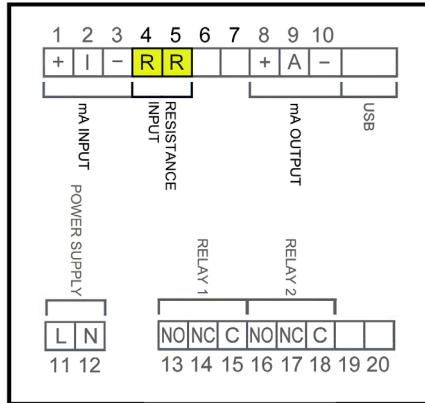

Terminal

- 4** Resistance
- 5** Resistance

This input is compatible with level transmitters of series LE and transmitters LTE of series LT, as well as with other level transmitters based on resistance variation with values between 0 and 6500 Ω.

3.2.3 Current input wiring

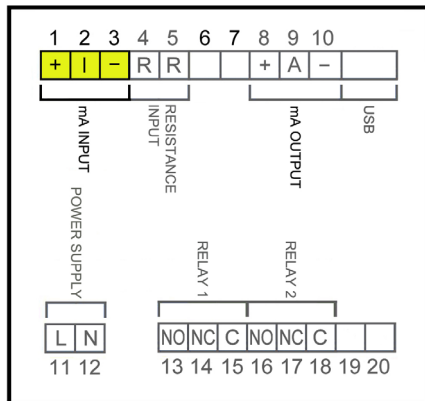

Terminal

- 1 mA (positive, power supply for a passive device)
- 2 mA input
- 3 mA (negative, input from an active device)

This input is compatible with any flow rate transmitter that provides a 4-20 mA output.

The impedance is 120 Ω. The input has a protection in order to limit the voltage applied to the circuit.

In the event that the current transmitter is passive, for example a 2-wire transmitter, it is necessary to power the current loop. It is done by connecting the transmitter to terminals 1 and 2.

If the current transmitter is active, the connection is between terminals 2 and 3.

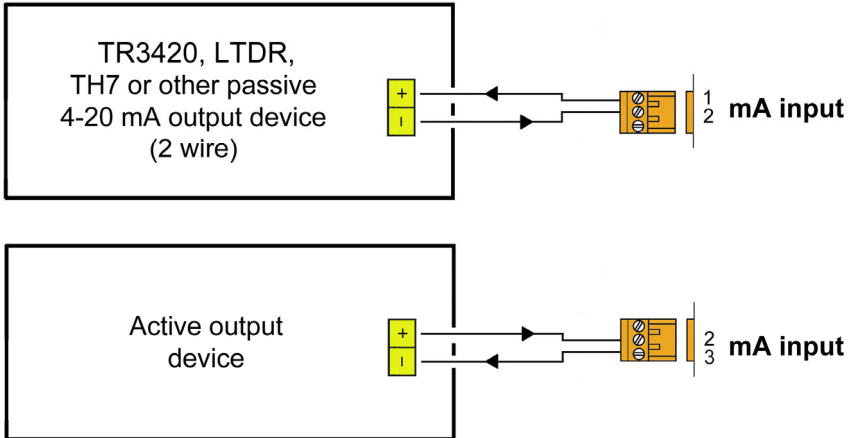

3.2.4 Analog output wiring

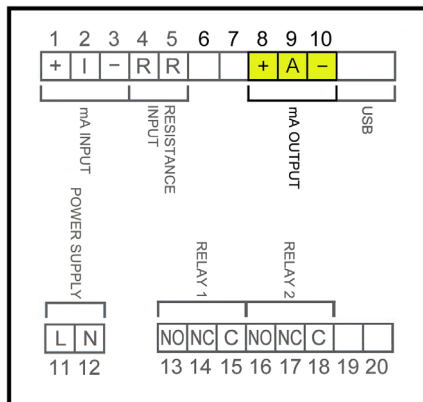

Terminal

8	mA (positive, active output)
9	mA
10	mA (negative, passive output)

The analog output is galvanically isolated. It can be either active (which means that the receiving device must be passive) or passive (which means that the receiver must supply the power for the current loop). It is recommended to use a receptor with an input resistance of less than 700 Ω to guarantee correct operation.

The configuration of the analog output mode (active or passive) is done by means of the connection to the terminal strip. For active mode, terminals 8 and 9 are connected. For passive mode, terminals 9 and 10 are connected.



NOTE: The analog output has a protection against reversed polarity. Due to another protection against over voltages, if a loop supply voltage of more than 36 V is connected the equipment may be damaged.

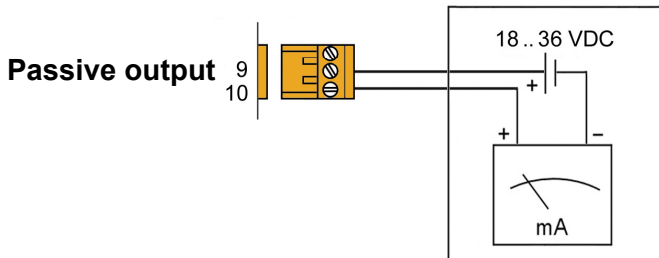
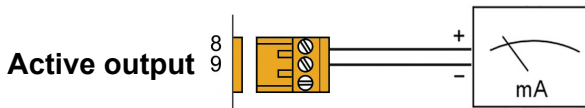

3.2.5 Relay output wiring

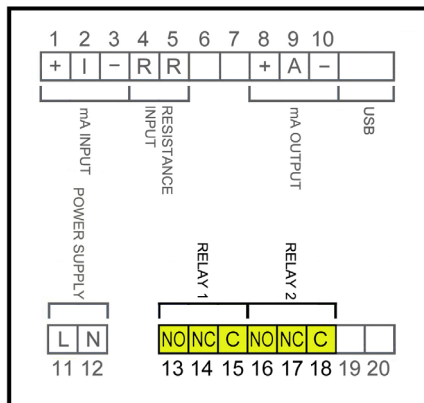

<u>Terminal</u>	<u>Description</u>	<u>Relay</u>
13	Normally open	Relay 1
14	Normally closed	Relay 1
15	Common	Relay 1
16	Normally open	Relay 2
17	Normally closed	Relay 2
18	Common	Relay 2

The relay outputs provide relays with potential free contacts (see characteristics on page 29).

The status of the relay contacts corresponds to the relay at rest.

The relay contacts are not protected in any way, and therefore they must be installed externally as required in the application, taking into account the limitations of the characteristics of such contacts.

In the case of having inductive loads, and to extend the working life of the relay contacts, it is recommended to use overvoltage protection (VDR for AC and diodes for DC loads). In all cases a fuse or some kind of protection against short circuits, should always be provided according to the needs of the intended load.

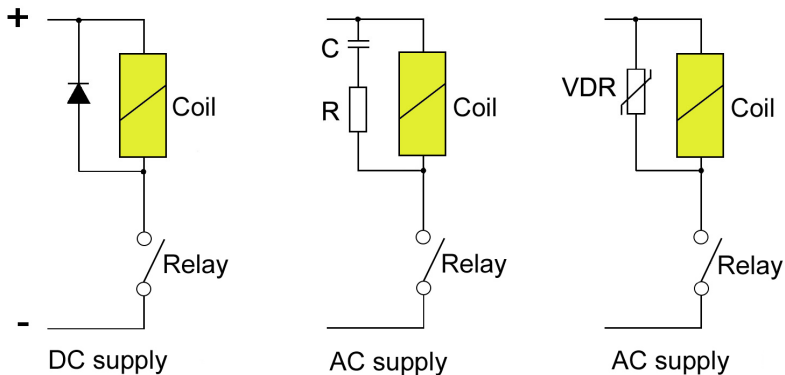

4 OPERATION

The MT03L converters have a graphic LCD and a keyboard with 4 push buttons.

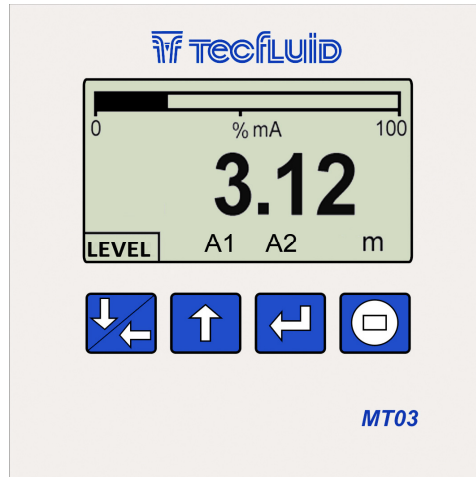

The following figure shows the functionality of the converter keys.



(Down / Left)
To change to the digit on the left.
Into the menu, to scroll down.



(Up)
To increase the digit.
To change the decimal point.
Into the menu, to scroll up.



(Enter) To validate the data.
To enter into installation and
programming modes of the converter.
To exit from an informative text.

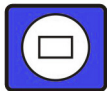

(Escape)
To return to the previous menu. To exit
from a screen without validating data.

5 MAIN MENU

To access the main menu of the converter, press the key (Enter). The following screen appears:

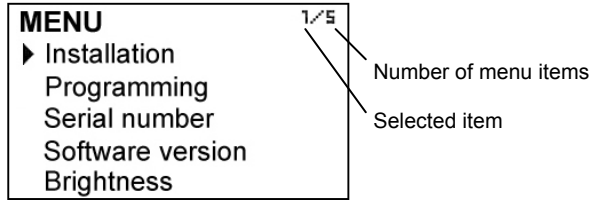

The "Installation" option allows the basic configuration of the instrument, as explained in Chapter 6 of this manual.

The "Programming" option allows to program all parameters of the converter, as explained in Chapter 7 of this manual.

The options "Software Version" and "Serial Number" are informative and are discussed in Chapters 8 and 9 of this manual.

5.1 Passwords to access the menus

The password for the installation menu may be different from the password for the program menu.

By default, the equipment is factory configured with the password disabled.

If you want to change any of these passwords, you must enter the corresponding menu and once inside, access the submenu "Password".

To change the access password of the installation menu, select "Installation" on the main menu and then "Password".

To change the access password of the programming menu, select "Programming" in the main menu and then "Password".

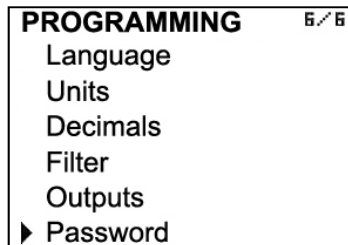
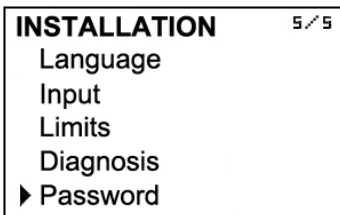

When the "Password" option is selected, a screen that indicates the password status for this menu appears.

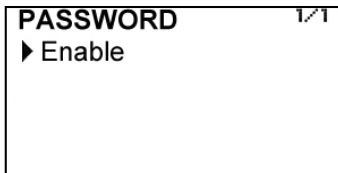

Selecting "Activate", the screen to enter the new password appears.

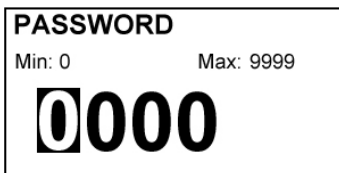

Once entered, the new password is asked again to avoid possible inadvertent error.



If the re-entered password does not match the first one, the following error message appears and the process should be carried out again.

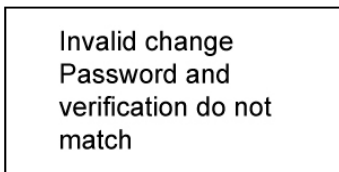

If both passwords match, the following information message is displayed:

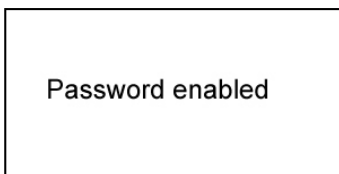

If the password needs to be changed or disabled, the procedure is the same. Once entered the "Password" menu, the following screen appears:

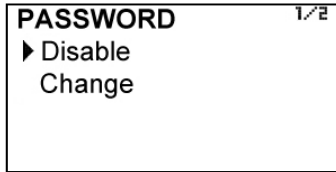

If Change is selected, the equipment will ask for a password again. If Disable is selected, the following message will appear:

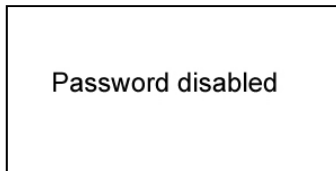

6 INSTALLATION PARAMETERS

Power on the electronic converter with the voltage indicated on the label.

Press the (Enter) key in order to enter the main menu.

With the keys (Down / Left) and (Up), select "Installation", and then validate with the key (Enter).

If the converter has the password option enabled, a password must be entered. For more details about the password, see section 5.1 on page 12.

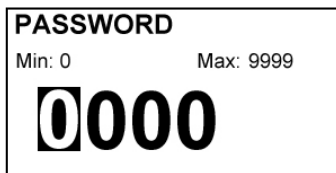

Once in the installation menu, the first screen allows to choose between the different options.

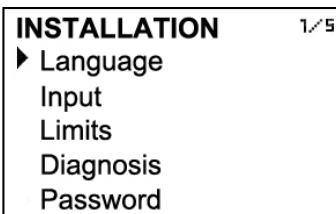

6.1 Language

You can choose the language in which all the menus will be displayed.

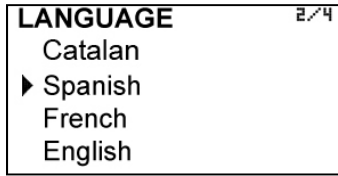

6.2 Input

In this screen the type of signal from the sensor connected to the MT03L can be chosen.

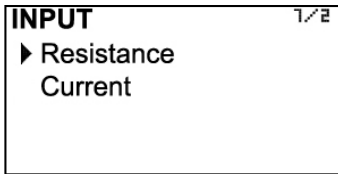

Resistance input is compatible with level transmitters of series LE and transmitters LTE of series LT, as well as with other level transmitters based on resistance variation.

Current input is compatible with level transmitters of series LP and LTDR, as well as with other level transmitters based on 4-20 mA output.

6.3 Limits

They set the relationship between the converter input signal and the displayed value.

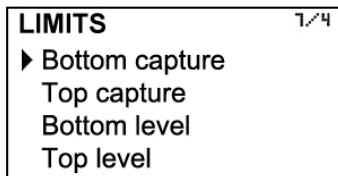

6.3.1 Capture

This option is recommended only for those MT03L converters with resistance input, and which must be connected to a level transmitter not purchased together with the converter or from another manufacturer.

If the MT03L converter has been acquired together with a Tecfluid level meter, lower and upper limit capture options are already configured at factory and their programming is not recommended.

If the converter is connected to a level transmitter through the current input, captures will not be normally necessary.

To perform the capture options, set the level meter at the lower limit position (e.g. float in its lowest position) and select the "Capture inf." with the key "Enter". The following confirmation screen appears.

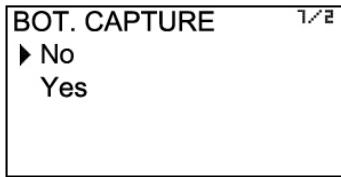

Selecting Yes, the device reads the input signal and sets the lower limit level.

The same procedure can be done with the capture of top level, placing the level meter at the upper limit position.

6.3.2 Distance adjustment

The distance adjustment associates the level values previously captured with actual distances, so that the converter can display the correct value.

In the same way as in the previous section, if the MT03L converter has been purchased with a Tecfluid level meter, the distance adjustment is done at the factory. It is not recommended to change these values.

In case of connection to a level meter previously acquired or from another manufacturer, if the capture process has been already made (6.3.1), with the last two options of the menu, the numeric values associated with the top and bottom level respectively can be entered.

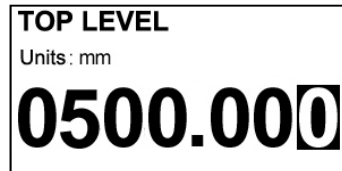
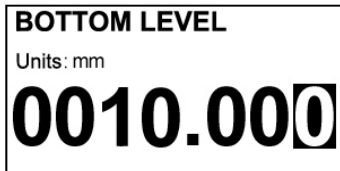

NOTES: The values of lower and upper level are always entered in millimetres.

It is mandatory that the bottom level value is smaller than the top level value.

6.4 Diagnosis

It allows to check some parameters of the equipment.

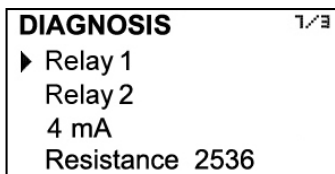

Pressing the key (Enter) while selecting Relay 1 or Relay 2 will activate or deactivate this output. When the relay is ON, the word is shown in reverse text.

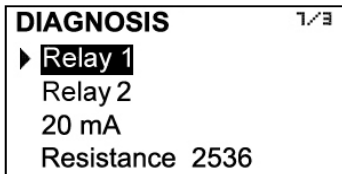

If 4 mA is selected, pressing the key (Enter) toggles between 4, 8, 12, 16 and 20 mA, allowing to check the adjustment of the analog output.

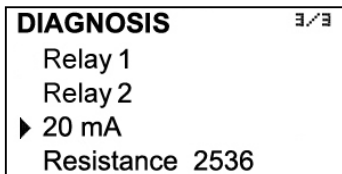

Finally, in the last row, the selected input type and a number that is related to the value of that input is shown. If when the level changes this number also changes, it means that the converter receives signal from the level sensor.

7 PROGRAMMING PARAMETERS

By programming the converter, the visualization and the outputs of the instrument can be configured.

Turn on the converter and press (Enter) to enter the main menu. The following screen appears:

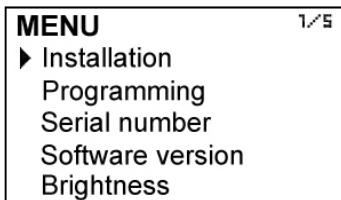

With the keys (Down / Left) and (Up), select Programming, and then validate with the key (Enter).

If the converter has the password option enabled, a password must be entered. For more details about the password, see section 5.1 on page 12.

Once in the programming menu, the first screen allows to choose between the different options.

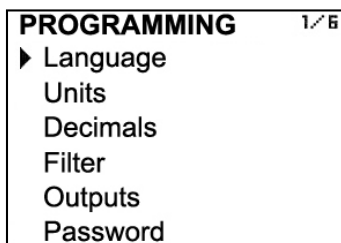

7.1 Language

You can choose the language in which all the menus will be displayed.

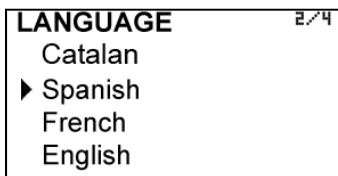

7.2 Units

In this screen the units for the level indication can be chosen.

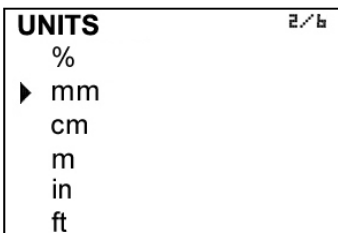

7.3 Decimals

In this screen the number of decimals for the level indication can be selected.

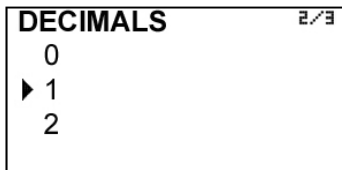

To select the number of decimals it must be taken into account that the instrument has 5 digits for level rate indication. If two decimals have been selected, these will be seen whilst the level is not higher than 999.99. Above this value the indication will automatically change to one decimal, and when the level is higher than 9999.9 the indication will be done without decimals.

If one decimal is selected, the level indication will have a maximum of one decimal until 9999.9. Above this value the indication will be done without decimals.

If indication without decimals is selected, the level will always be shown without decimals.

For the selection of the level units and the number of decimals it must be taken into account that an indication with an excess of decimals may give the sensation of instability of the reading. As a general rule it can be considered that the reading should not have more than a total of 5 digits (integer + decimals).

7.4 Damping

The MT03L converter has an adaptive filter (damping) to provide stable level and analog output readings in the presence of continuous level fluctuations.

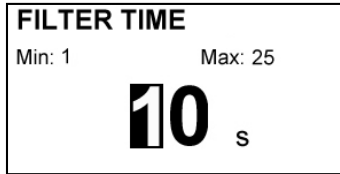

The configuration of this filter can be very useful in the cases where the level readings have some instability (due to for example waves in the tank).

Only the level indication of the display and the analog output are affected by the filter. The relay output acts according to the instant level. Selecting a filter with a longer or shorter integration time will provide more or less stable readings and will also affect the response time to small variations of level.

The integration time is selected in seconds, with a minimum value of 0 and a maximum value of 25 seconds. For example, with an integration time of 15 seconds, the display will indicate the level reading of the average level over the last 15 seconds from the last update of the display. This does not mean that the display is refreshing its data every 15 seconds. The display shows a new value several times per second, indicating an average of the level values of the last 15 seconds.

7.5 Outputs

This screen allows to program the three outputs of the instrument: Relay 1, Relay 2 and analog output (4-20 mA).

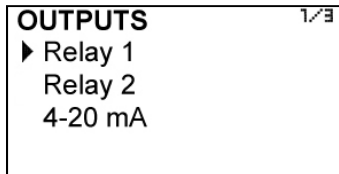

7.5.1 Relay 1 and relay 2

By selecting one of the two relay outputs, next screen appears with the options which allow to assign the relay to a function.

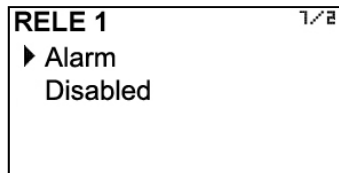

7.5.1.1 Alarm

If Alarm is selected, we have access to program the level value at which the relays will change its status and to the level of hysteresis. By level of hysteresis we understand the difference between activation and deactivation of the output. To avoid that an alarm output is continuously moving from activate to deactivate status, we must program the points of connection and disconnection.

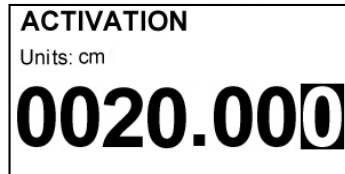
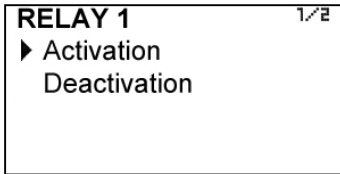

Example 1

If the activation point is programmed to 100 cm and the deactivation point is programmed to 90 cm, when the level is zero the output will be deactivated. When the level reaches a value of 100 cm the output will be activated until the level falls below 90 cm.

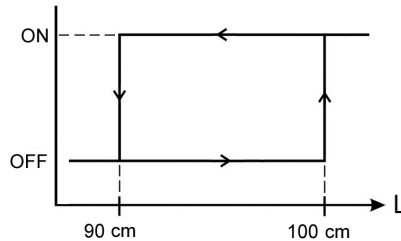

Example 2

If we program an activation point of 90 cm and a deactivation point of 100 cm, when the level is zero the output will be activated. When level reaches a value of 100 cm the output will be deactivated until the level falls below 90 cm.

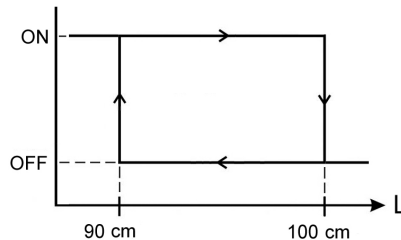

7.5.1.2 No action

The relay will be always at rest.

7.5.2 Analog output

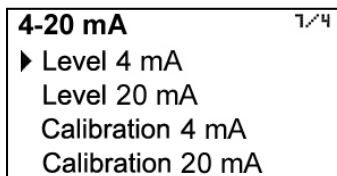

The level value corresponding to 4 mA and 20 mA can be programmed and the calibration for these two values can be made as well.

7.5.2.1 Programming of the 4-20 mA output

Level values equivalent to each current are entered directly.

Programming a level value for 20 mA higher than the one for 4 mA, the loop current changes from 4 to 20 mA as the level increases.

Otherwise, programming a level value for 20 mA lower than the one for 4 mA, the current loop will change from 20 to 4 mA as the level increases.

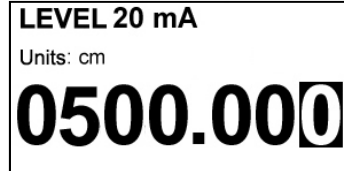
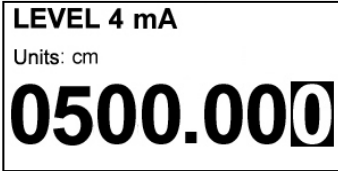

7.5.2.2 Current calibration for 4 and 20 mA

The MT03L converter is delivered with the current output already calibrated. If you want to correct a derive of the 4 or 20 mA current values because they do not coincide with the ammeter used, it can be done by entering the ammeter value and pressing the key (Enter). The ammeter will indicate the new value and the MT03L screen will show the values of 4 or 20 mA again in the event the operation needs to be done again. More than one adjustment can be necessary to do a complete calibration.

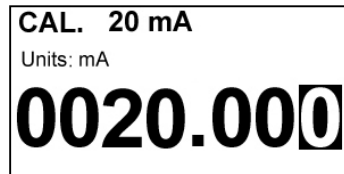
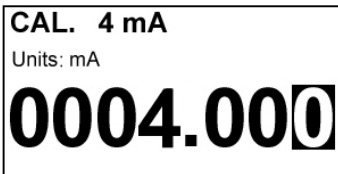

Before making a current calibration, be sure that the ammeter used for that is showing a correct value.

8 SERIAL NUMBER



In this section the converter serial number is shown.

9 SOFTWARE VERSION

From the main menu, if “Software version” is selected, the screen will show this data and the corresponding date.

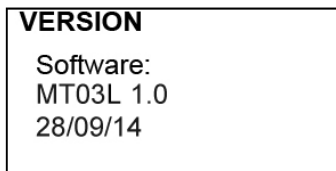

10 BRIGHTNESS

With this option the screen backlight can be adjusted.

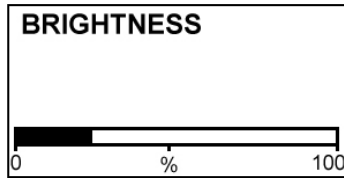

11 WORKING SCREEN

When exiting the menu, the display shows the working screen, indicating the level value in the previously selected units.

This screen shows the relay output status, if they are activated.

An "A" will appear in normal or reverse format depending on the relay status.

12 MAINTENANCE

No special maintenance is required.

12.1 Fuse

The device has a $\varnothing 5 \times 20$ mm fuse as a protection at power supply input. The fuse rating depends on the nominal supply voltage.

In the event that the fuse blows, this should be replaced with one of the same value.

13 ASSOCIATED SOFTWARE WINSMETER MT03

Most of the steps in the preceding paragraphs can be done by means of the device associated software Winsmeter MT03, which allows working in a more comfortable and intuitive way.

Such software can be downloaded from the "Downloads" section of the Tecfluid S.A. www.tecfluid.com/downloads

13.1 USB cable connection and drivers installation

Extract the files from the winsmeter MT03.zip to a new system folder.

Execute the Setup.exe file and follow the steps for the installation.

In order to connect the converter to a computer an USB cable is required. This cable is type A at one end and type B at the other, and it is readily available on the market.

The ends of the cables can be seen in the picture.



The USB connector is located at the rear side of the converter.

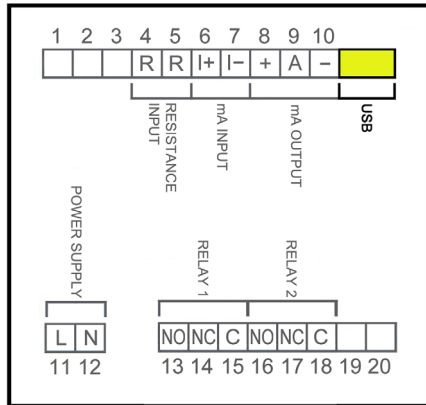

Connect the USB cable at one end to the converter and at the other to the computer where the software is installed.

Power on the electronic converter.

Execute the program WinsmeterMT03 following the sequence Start – Programs – Tecfluid S.A. - WinsmeterMT03.

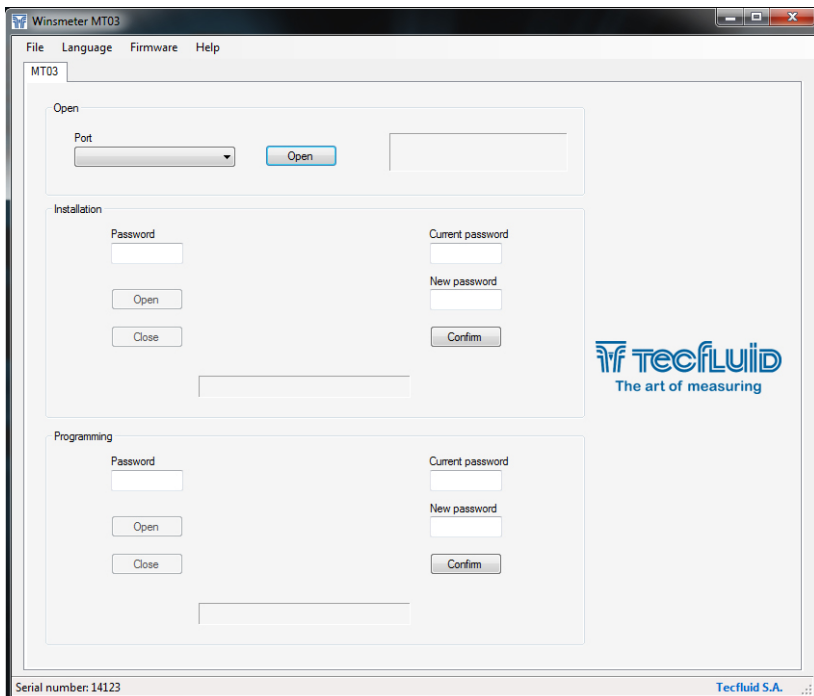

13.2 Port connection

In the "Port" section, choose the appropriate port for the converter. This will appear with the name of the port followed by MT03L and its serial number. Then click "Open".

Once the port is open, the button "Open" in the "Installation" and "Programming" sections activates.

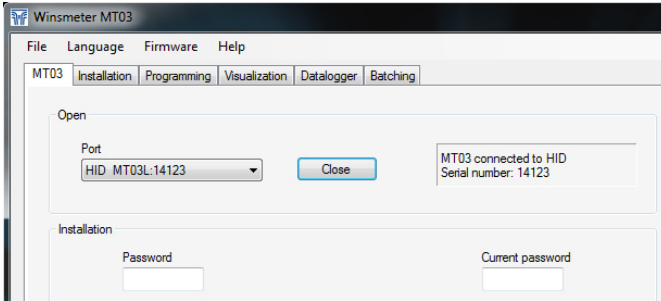

13.3 Access to installation and programming

In order to change the data contained in the "Install" tab, you must enter a password.

The default password is **install**, and it can be changed using the boxes on the right of the "Installation" section.

Likewise, to change the data contained in the "Programming" it is necessary to enter the password which by default is **program**. This can be changed using the boxes on the right of the "Programming" section.

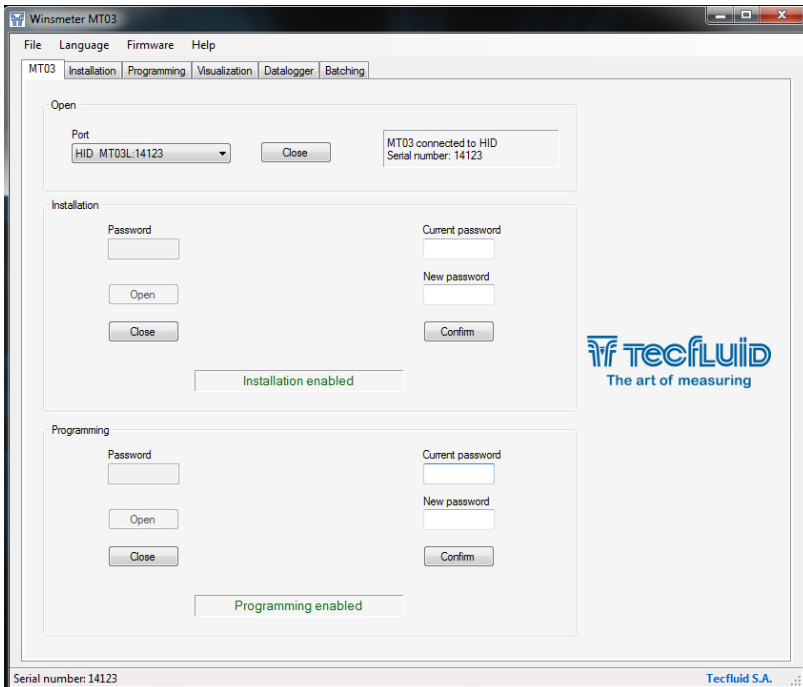

Once the password is written, press "Enter" or "Open", and the installation or programming tab will open. At the bottom of each section the text "Installation tab open" or "Programming tab open" will be displayed

To enter the Installation window, just click the corresponding tab.

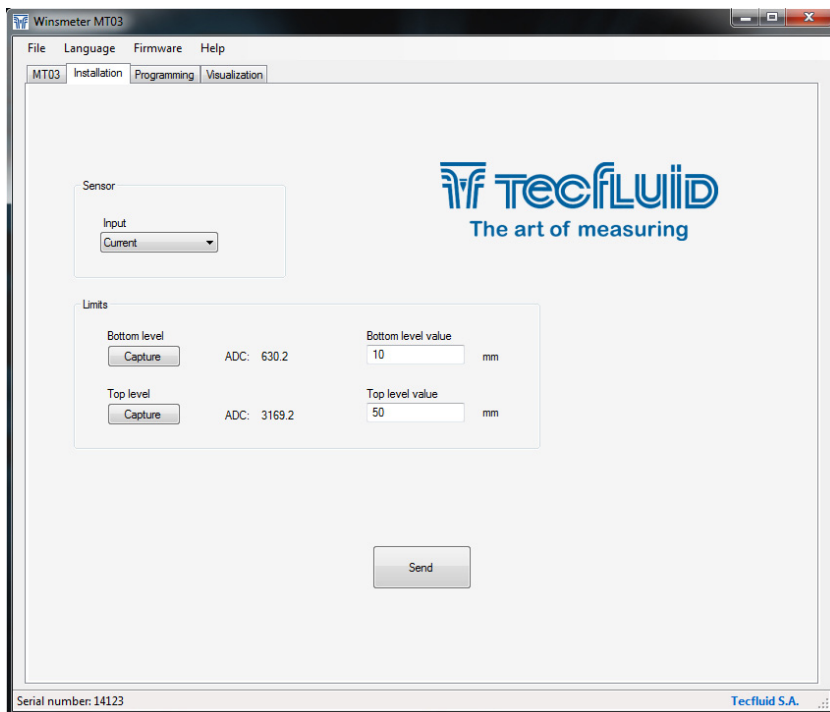

In the installation window the parameters that adapts the converter to a sensor can be configured.

To transfer data to the MT03L converter, press the "Send" button. The message "Saving program" will appear for two seconds in the converter screen. The installation data will be stored in the memory of the converter.

Likewise, to enter into the programming window, just click the corresponding tab.

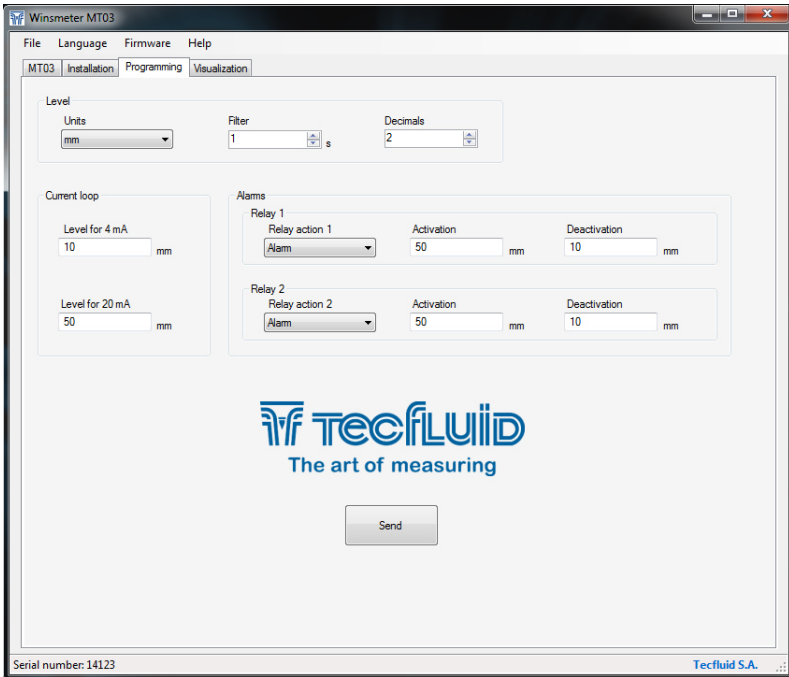

Changing the parameters of this screen you can program the different functions of the equipment.

As in the previous paragraph, to program this data to the MT03L converter, press the "Send" button. The message "Saving program" will appear for two seconds in the converter screen. The programming data will be stored in the memory of the converter.

13.4 Visualization

When the communication with the computer port is established (see section 13.2), the tab "Visualization" opens. This tab lets you view real-time level value, as well as the current value of the analog output and the status of the relay outputs.

It is an intuitive tool to verify that the instrument has been installed and programmed correctly.

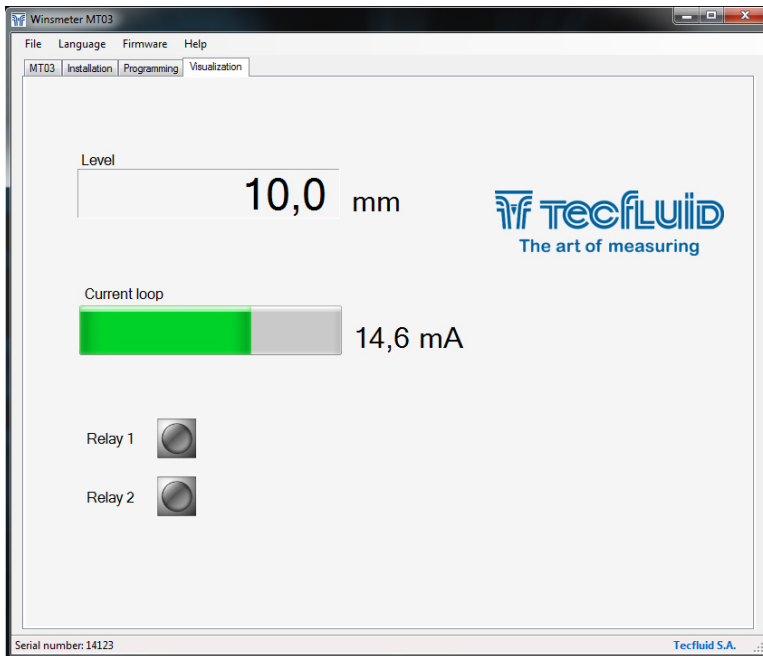

13.5 Firmware updates

New firmware updates can be published in the website. These updates contain improvements or bug fixes that make the equipment operates at best conditions.

The updates can be downloaded from the following link of Tecfluid S.A. website www.tecfluid.com/download

To update the equipment, go to menu "Firmware" - "Update", and a screen with the button "File" will appear. Pressing this button file explorer can be accessed. The downloaded file has to be searched there.

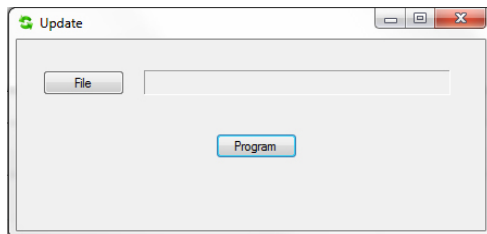

Once the file is selected, press the “Program” button. A message “Programming device” will appear.

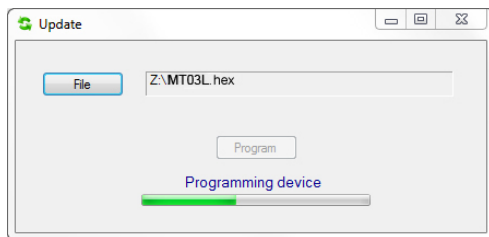

The process takes about 90 seconds, after which the message “Device programmed” will appear.

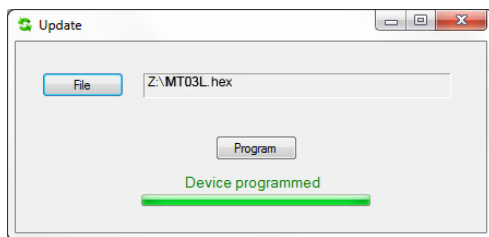

From this moment, the converter MT03L already has the new version of Firmware.

14 TECHNICAL CHARACTERISTICS

Power supply

90 ... 265 VAC 50, 60 Hz

18 ... 36 VDC

Power consumption: ≤ 5 VA

Resistance input

Range: 0 ... 6500 Ω

Resolution: 2 Ω

Current input

Range: 4 ... 20 mA

Resolution: 7 μ A

Analog output

4-20 mA. Active or passive. Galvanically isolated from the power supply.

Relay outputs

2 relays with potential free contacts.

Contact characteristics:

Maximum voltage : 220 VDC, 250 VAC

Maximum current: : 3 A

Level indication

N° of digits: 5 (up to 2 decimals configurable)**

Digit size: 11 mm

** When the available digits are full and the integers overflow a decimal is automatically lost.

Ambient temperature range:

-20°C ... +60 °C

Housing

Material:

Box: Noryl SE1, GFN2, 701 black ⁽¹⁾

Front frame: Lexan 920 black ⁽¹⁾

Ingress protection:

Back side: IP30

Front side: IP50

Silicone sleeves for the front side are available. They provide an IP65 ingress protection.

Conforms to Low voltage Directive 2006/95/CE

Conforms to Electromagnetic compatibility Directive 2004/108/CE

Conforms to Waste Electrical and Electronic Equipment Directive 2002/96/CE



⁽¹⁾ Noryl and Lexan are trademarks of Saudi Basic Industries Corporation (SABIC).

15 DIMENSIONS

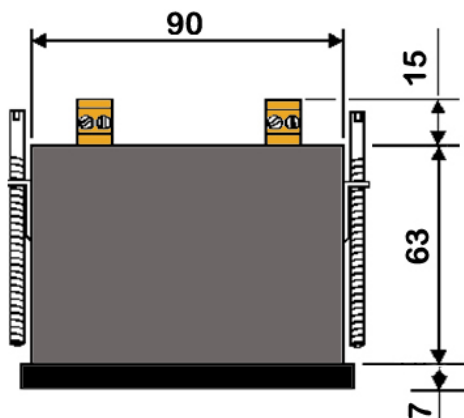
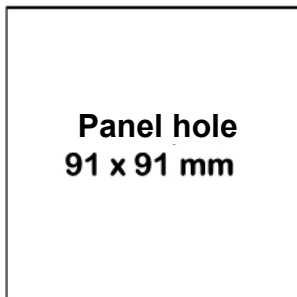
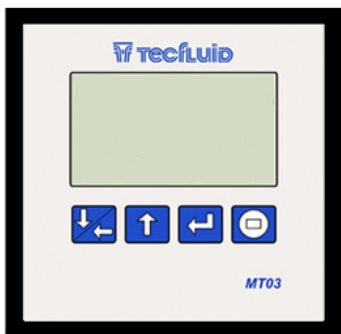

16 TROUBLESHOOTING

Problem	Probable cause	Solution
The displayed level is 0	Incorrect input	Check that the input type programmed in the menu matches the connection made (see page 15)
	Cable disconnected	Connect the cable between the level sensor and the MT03L
The display is blank	Blown fuse	Change the fuse
The analog output provides always 4 mA or 20 mA	Current output range not properly programmed	Program the range properly (see page 20)
The analog output provides always 0 mA	Cable disconnected	Check the cable connection

WARRANTY

Tecfluid S.A. guarantees all the products for a period of 24 months from their sale, against all faulty materials, manufacturing or performance. This warranty does not cover failures which might be imputed to misuse, use in an application different to that specified in the order, the result of service or modification carried out by personnel not authorized by Tecfluid S.A., wrong handling or accident.

This warranty is limited to cover the replacement or repair of the defective parts which have not damaged due to misuse, being excluded all responsibility due to any other damage or the effects of wear caused by the normal use of the devices.

Any consignment of devices for repair must observe a procedure which can be consulted in the website www.tecfluid.com, "After-Sales" section.

All materials sent to our factory must be correctly packaged, clean and completely exempt of any liquid, grease or toxic substances.

The devices sent for repair must enclose the corresponding form, which can be filled in via website from the same "After-Sales" section.

Warranty for repaired or replaced components applies 6 months from repair or replacement date. Anyway, the warranty period will last at least until the initial supply warranty period is over.

TRANSPORTATION

All consignments from the Buyer to the Seller's installations for their credit, repair or replacement must always be done at freight cost paid unless previous agreement.

The Seller will not accept any responsibility for possible damages caused on the devices during transportation.



Tecfluid S.A.

Narcís Monturiol 33
08960 Sant Just Desvern
Barcelona

Tel: +34 93 372 45 11
Fax: +34 93 473 44 49
tecfluid@tecfluid.com

www.tecfluid.com

Quality Management System ISO 9001 certified by



Pressure Equipment Directive 97/23/CE certified by



ATEX European Directive 94/9/CE certified by



The technical data described in this manual is subject to modification without notification if the technical innovations in the manufacturing processes so require.