



### Mass flow controller (MFC)/mass flow meter (MFM) for gases

- Nominal flow ranges from 20 l/min up to 2500 l/min
- High measuring accuracy and repeatability with very fast response times
- Long-term stability of the flow calibration
- Simpler device exchange due to configuration memory
- Optional: ATEX II Cat. 3G/D or USP Class VI, FDA, EC 1935 conformity

Product variants described in the data sheet may differ from the product presentation and description.

#### Can be combined with

	<b>Type 6013</b> Plunger valve 2/2-way direct-acting	▶
	<b>Type 6027</b> Direct-acting 2/2-way plunger valve	▶
	<b>Type 0330</b> Direct-acting 2/2 or 3/2-way pivoted armature valve	▶
	<b>Type 0290</b> Servo-assisted 2/2-way diaphragm valve	▶
	<b>Type ME43</b> Fieldbus gateway	▶
	<b>Type ME63</b> Industrial Ethernet gateway, IP65/ IP67/ IP69k	▶

#### Type description

The Mass flow controller (MFC) / mass flow meter (MFM) Type 8746 for gases is suitable for a wide range of applications, e.g. metal and glass manufacturing or processing, fermentation processes, test benches or filling systems and packaging machines. Type 8746 is available in two variants: A variant with several analogue or digital (communication) interfaces and a variant with a pure CANopen-based interface. The latter is suitable for integration in existing CANopen networks or - in combination with a Bürkert fieldbus gateway - for integration in all common industry standards for Industrial Ethernet or fieldbus. This variant is tailor-made for applications with many control loops. Up to 32 MFCs / MFMs can be connected to one fieldbus gateway. The gateway transmits the internal CANopen-based communication to Industrial Ethernet and fieldbus standards. The Mass flow controller / mass flow meter can always be switched between bus and CANopen communication. Type 8746 can be configured as an MFM or an MFC according to demand. Optionally, up to four calibration curves can be stored in the device. The thermal inline sensor is located directly in the main flow and achieves fast response times and a high level of measuring accuracy with long-term stable calibration. As the actuator, a Bürkert direct-acting, electromagnetic proportional valve or motor valve guarantees high response sensitivity. The integrated PI controller ensures excellent control characteristics of the MFC. Type 8746 is characterised by low pressure drop, even at high flow rates, and is especially designed for use in harsh environments thanks to its high IP protection class and explosion protection.

DTS 1000241027 EN Version: X Status: RL (released | freigegeben | validé) printed: 29.04.2024

## Table of contents

<b>1. General technical data</b>	<b>4</b>
1.1. General.....	4
1.2. Variant with electromagnetic proportional valve.....	4
1.3. Variant with electromotive proportional valve.....	5
<b>2. Approvals and conformities</b>	<b>6</b>
2.1. General notes.....	6
2.2. Conformity.....	6
2.3. Standards.....	6
2.4. Explosion protection.....	6
2.5. North America (USA/Canada).....	6
2.6. Foods and beverages/Hygiene.....	6
2.7. Oxygen.....	6
<b>3. Materials</b>	<b>7</b>
3.1. Bürkert resistApp.....	7
<b>4. Dimensions</b>	<b>8</b>
4.1. Thread depths of base blocks.....	8
MFC or MFM for small nominal flow rates.....	8
MFC or MFM for large and very large nominal flow rates.....	8
4.2. Variant with electromagnetic proportional valve and büS/CANopen interface.....	8
MFC with valve Type 2873.....	8
MFC with valve Type 2875.....	9
MFC with valve Type 2836.....	10
4.3. Variant with electromotive proportional valve and büS/CANopen interface.....	13
MFC with valve Type 3280.....	13
MFC with valve Type 3285 (DN 12 and DN 15).....	14
MFC with valve Type 3285 (DN 20 and DN 25).....	15
4.4. MFM variant with büS/CANopen interface.....	16
Variant with base block 00 or A1 for small nominal flow rates.....	16
Variant with base block A2 for large nominal flow rates.....	17
Variant with base block A3 for very large nominal flow rates.....	17
4.5. Variant with electromagnetic proportional valve and analogue or PROFIBUS DPV1 interface.....	18
MFC with valve Type 2873.....	18
MFC with valve Type 2875.....	19
MFC with valve Type 2836.....	20
4.6. Variant with electromotive proportional valve and analogue or PROFIBUS DPV1 interface.....	23
MFC with valve Type 3280.....	23
MFC with valve Type 3285 (DN 12 and DN 15).....	25
MFC with valve Type 3285 (DN 20 and DN 25).....	26
4.7. MFM variant with analogue or PROFIBUS DPV1 interface.....	27
Variant with base block 00 or A1 for small nominal flow rates.....	27
Variant with base block A2 for large nominal flow rates.....	28
Variant with base block A3 for very large nominal flow rates.....	28
4.8. Variant with Industrial Ethernet interface.....	29
<b>5. Device/Process connections</b>	<b>30</b>
5.1. büS/CANopen.....	30
5.2. Industrial Ethernet.....	30
5.3. Analogue.....	30
5.4. PROFIBUS DPV1.....	31

DTS 1000241027 EN Version: X Status: RL (released | freigegeben | validé) printed: 29.04.2024

<b>6. Performance specifications</b>	<b>32</b>
6.1. MFM pressure loss diagram .....	32
6.2. Nominal flow range of typical gases .....	32
6.3. Derating diagram for electromotive variants .....	33
<b>7. Product operation</b>	<b>33</b>
7.1. Measuring principle.....	33
<b>8. Product design and assembly</b>	<b>34</b>
8.1. Measures to comply with ATEX requirements .....	34
<b>9. Product accessories</b>	<b>35</b>
9.1. Bürkert Communicator software.....	35
9.2. Connecting Type 8746 with the Bürkert Communicator software.....	36
9.3. Configuration management for easy device replacement .....	36
9.4. Web server for Industrial Ethernet variant.....	36
<b>10. Ordering information</b>	<b>36</b>
10.1. Bürkert eShop .....	36
10.2. Recommendation regarding product selection.....	36
10.3. Bürkert product filter .....	37
10.4. Bürkert Product Enquiry Form .....	37
10.5. Ordering chart accessories.....	37

## 1. General technical data

### 1.1. General

Product properties	
Dimensions	Further information can be found in chapter "4. Dimensions" on page 8.
Material	
Seal	FKM or EPDM (depending on gas) <sup>1.)</sup>
Housing	Die-cast aluminium (coated)
Base block	Aluminium or stainless steel 1.4404/316L
Configuration management	Further information can be found in chapter "9.3. Configuration management for easy device replacement" on page 36.
Electrical data	
Operating voltage	24 V DC
Residual ripple	± 2 %
Voltage tolerance	± 10 %
Electrical connection	
büS/CANopen variant	M12 plug, 5-pin
Analogue variant	M12 plug, 5-pin, M12 socket, 5-pin
Industrial Ethernet variant	M12 plug, 5-pin, 2 x M8 socket, 4-pin
PROFIBUS DPV1 variant	M12 plug, 5-pin, M12 socket, 5-pin
Medium data	
Operating medium	Neutral, pure gases (others on request)
Calibration medium	Operating medium or air
Medium temperature	- 10 °C <sup>2.)</sup> ...+ 70 °C (- 10 °C <sup>2.)</sup> ...+ 60 °C with oxygen)
Process/Port connection & communication	
Analogue interface	4...20 mA, 0...20 mA, 0...10 V or 0...5 V Input impedance: >20 kΩ (voltage) resp. <300 Ω (current) Maximum current: 10 mA (voltage output) Maximum load: 600 Ω (current output)
Digital communication interface	büS/CANopen, PROFIBUS DPV1, Industrial Ethernet: EtherCAT®, EtherNet/IP, Modbus TCP
Port connection	G ¼, NPT ¼, ⅜", ½", ¾", 1", sub-base
Approvals and conformities	
Protection class	IP65
Certificate	Material certificate 3.1 (optionally)
Explosion protection	Further information can be found in chapter "2.4. Explosion protection" on page 6.
North America (USA/Canada)	Further information can be found in chapter "2.5. North America (USA/Canada)" on page 6.
Foods and Beverages/Hygiene	Further information can be found in chapter "2.6. Foods and beverages/Hygiene" on page 6.
Oxygen	Further information can be found in chapter "2.7. Oxygen" on page 6.
Environment and installation	
Installation position	Horizontal or vertical
Ambient temperature	- 10 °C...+ 50 °C (higher temperatures on request)
Accessories	
Software	Bürkert Communicator Further information can be found in chapter "9.1. Bürkert Communicator software" on page 35.

1.) In addition, when using the electromotive proportional valve:

- Type 3280 DN 4: PEEK valve seat seal
- Type 3285: Al<sub>2</sub>O<sub>3</sub> valve seat seal

2.) When using the electromotive proportional valve, the minimum medium temperature is 0 °C.

### 1.2. Variant with electromagnetic proportional valve

Type 8746 can be configured as MFC or MFM as required. The MFC variant uses direct-acting proportional valves of the 287x series. These electromagnetic proportional valves are normally closed and stand for highest measuring accuracy and repeatability with settling times resp. response times of a few hundred milliseconds.

Product properties	
Dimensions	Further information can be found in chapter "4. Dimensions" on page 8.

Total weight	Approx. 1800 g (aluminium, 16 W valve) Approx. 3100 g (stainless steel, 16 W valve)
LED display <sup>1.)</sup>	RGB LED according to NAMUR NE107
<b>Control valve (proportional valve)</b>	<b>Normally closed</b>
Valve orifice	0.8...12 mm
K <sub>VS</sub> value range	0.02...2.5 m <sup>3</sup> /h
<b>Performance data</b>	
Nominal flow range (Q <sub>N</sub> )	MFC: 20...1500 l/min (N <sub>2</sub> ) MFM: ≤2500 l/min (N <sub>2</sub> )
Maximum operating pressure (overpressure to atmospheric pressure)	MFM: 10 bar, optionally ≤25 bar For MFCs, the maximum operating pressure depends on the medium and nominal valve size.
Measuring accuracy <sup>2.)</sup>	± 1.5 % of reading ± 0.3 % FS (under calibration conditions)
Repeatability	± 0.1 % FS
Measuring span	1:50
Settling time (MFC)/Response time (MFM) (t <sub>95%</sub> )	< 500 ms
<b>Electrical data</b>	
Power consumption <sup>3.)</sup>	MFM: max. 2 W MFC: max. 10.5...29.5 W (depending on the proportional valve type)

1.) For a detailed description of LED colours see [operating instructions Type 8746](#) ▶.

2.) If the operating medium is different from the calibration medium, the actual measurement accuracy might vary from the indicated value. If the operating medium is natural gas, the measurement accuracy depends on the composition of the natural gas, which can vary depending on the origin and season.

3.) Information in relation to the typical power consumption (at +23 °C ambient temperature, nominal flow and 30 min closed-loop control mode). Information according to UL 61010-1 may vary (see [operating instructions Type 8746](#) ▶).

### 1.3. Variant with electromotive proportional valve

Type 8746 with electromotive proportional valve is especially suitable for applications with high inlet pressures up to 22 bar or high flow rates (with low pressure loss). Thanks to their very low holding capacity, these valves can drastically reduce the less energy consumption of a system. When de-energised, the motor valves remain in position. The maximum duty cycle of the motor depends on the ambient temperature. The duty cycle is not the duty cycle of the appliance but the duty cycle of the motor. This is only switched on when the valve is to move. The motor's duty cycle increases drastically due to frequent changes in the set-point value. Further information about the derating curve can be found in the chapter [“6.3. Derating diagram for electromotive variants” on page 33](#).

<b>Product properties</b>	
Dimensions	Further information can be found in chapter <a href="#">“4. Dimensions” on page 8</a> .
Total weight	Approx. 1670 g (aluminium, valve Type 3280) Approx. 2940 g (stainless steel 1.4404/316L, valve Type 3280)
LED display <sup>1.)</sup>	With MFM: RGB LED according to NAMUR NE107 With valve: RGB LED to indicate valve opening
<b>Control valve (proportional valve)</b>	<b>Normally closed</b>
Valve orifice	2...20 mm
K <sub>VS</sub> value range	0.5...7.8 m <sup>3</sup> /h
<b>Performance data</b>	
Nominal flow range (Q <sub>N</sub> )	20...2500 l/min (N <sub>2</sub> )
Maximum operating pressure (overpressure to atmospheric pressure)	MFM: 22 bar For MFCs, the maximum operating pressure depends on the medium and nominal valve size.
Measuring accuracy <sup>2.)</sup>	± 2 % of reading ± 0.5 % FS (under calibration conditions)
Repeatability	± 0.5 % FS
Measuring span	1:50
Settling time (MFC)/Response time (MFM) (t <sub>95%</sub> ) <sup>2.)</sup>	< 5 s
<b>Electrical data</b>	
Power consumption	MFM: max. 2 W MFC: max. 10.5 W <sup>3.)</sup>

1.) For a detailed description of LED colours see [operating instructions Type 8746](#) ▶.

2.) If the operating medium is different from the calibration medium, the actual measurement accuracy might vary from the indicated value. If the operating medium is natural gas, the measurement accuracy depends on the composition of the natural gas, which can vary depending on the origin and season.

3.) Data during the movement of the electromotive proportional valve. Valve holding power is < 1 W.

## 2. Approvals and conformities

### 2.1. General notes

- The approvals and conformities listed below must be stated when making enquiries. This is the only way to ensure that the product complies with all required specifications.
- Not all available variants can be supplied with the below mentioned approvals or conformities.



### 2.2. Conformity

In accordance with the Declaration of Conformity, the product is compliant with the EU Directives.

### 2.3. Standards

The applied standards which are used to demonstrate compliance with the EU Directives are listed in the EU-Type Examination Certificate and/or the EU Declaration of Conformity.

### 2.4. Explosion protection

Approval	Description
 	<b>Optional: Explosion protection</b>  <b>ATEX:</b> <b>EPS 22 ATEX 1 277 X</b> II 3G Ex ec IIC T4 Gc II 3D Ex tc IIIC T135 °C Dc  <b>IECEx:</b> <b>IECEx EPS 22.0066X</b> Ex ec IIC T4 Gc Ex tc IIIC T135 °C Dc

### 2.5. North America (USA/Canada)

Approval	Description
	<b>Optional: UL Listed for the USA and Canada</b> The products are UL Listed for the USA and Canada according to: <ul style="list-style-type: none"> <li>• UL 61010-1 (ELECTRICAL EQUIPMENT FOR MEASUREMENT, CONTROL, AND LABORATORY USE – Part 1: General Requirements)</li> <li>• CAN/CSA-C22.2 No. 61010-1</li> </ul>

### 2.6. Foods and beverages/Hygiene

Conformity	Description
FDA	<b>FDA – Code of Federal Regulations (valid for variable code PL02, PL03)</b> All wetted materials are compliant with the Code of Federal Regulations published by the FDA (Food and Drug Administration, USA) according to the manufacturer’s declaration.
USP	<b>United States Pharmacopeial Convention (USP) (valid for variable code PL04)</b> All wetted materials are biocompatible according to the manufacturer’s declaration.
	<b>EC Regulation 1935/2004 of the European Parliament and of the Council (valid for variable code PL01, PL02)</b> All wetted materials are compliant with EC Regulation 1935/2004/EC according to the manufacturer’s declaration.

### 2.7. Oxygen

Conformity	Description
------------	-------------

DTS 1000241027 EN Version: X Status: RL (released | freigegeben | valide) printed: 29.04.2024

**O<sub>2</sub>****Optional: Suitability for oxygen (valid for the variable code NL02)**

The products are suitable for use with gaseous oxygen, according to the manufacturer's declaration.

### 3. Materials

#### 3.1. Bürkert resistApp

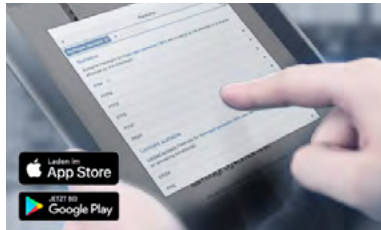
**Bürkert resistApp – Chemical Resistance Chart**

You want to ensure the reliability and durability of the materials in your individual application case? Verify your combination of media and materials on our website or in our resistApp.

[Start Chemical Resistance Check](#)

## 4. Dimensions

### 4.1. Thread depths of base blocks

MFC or MFM for small nominal flow rates

**Note:**

The following table applies to base blocks

Thread (A)	Thread depth [mm]
G ¼	12
NPT ¼	11
G ⅜	12
NPT ⅜	11
G ½	15
NPT ½	14
G ¾	16
NPT ¾	15

MFC or MFM for large and very large nominal flow rates

**Note:**

The following table applies to base blocks A2...A3.

Thread (A)	Thread depth [mm]
G ½	15
NPT ½	14
G ¾	16
NPT ¾	15
G 1	18
NPT 1	16.8

### 4.2. Variant with electromagnetic proportional valve and büS/CANopen interface

MFC with valve Type 2873

Variant with base block 00 or A1 for small nominal flow rates

**Note:**

Dimensions in mm

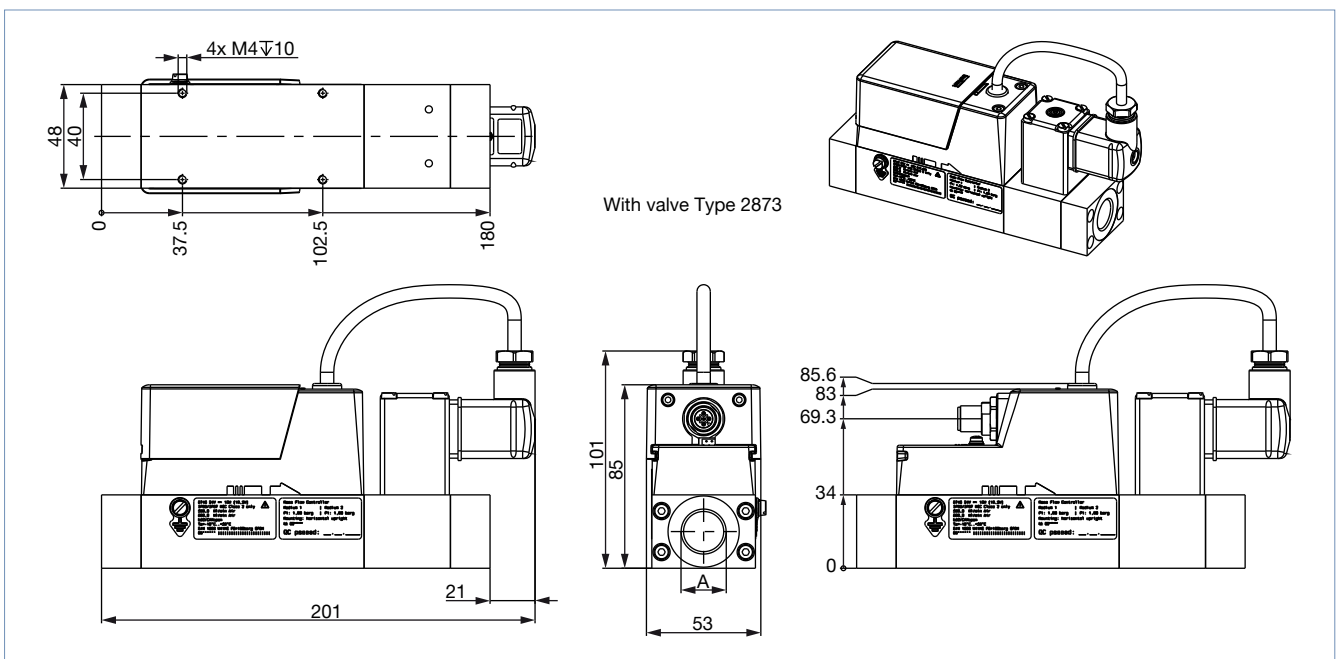

DTS 1000241027 EN Version: X Status: RL (released | freigegeben | valide) printed: 29.04.2024



**MFC with valve Type 2875**

**Variant with base block 00 or A1 for small nominal flow rates**

**Note:**

Dimensions in mm

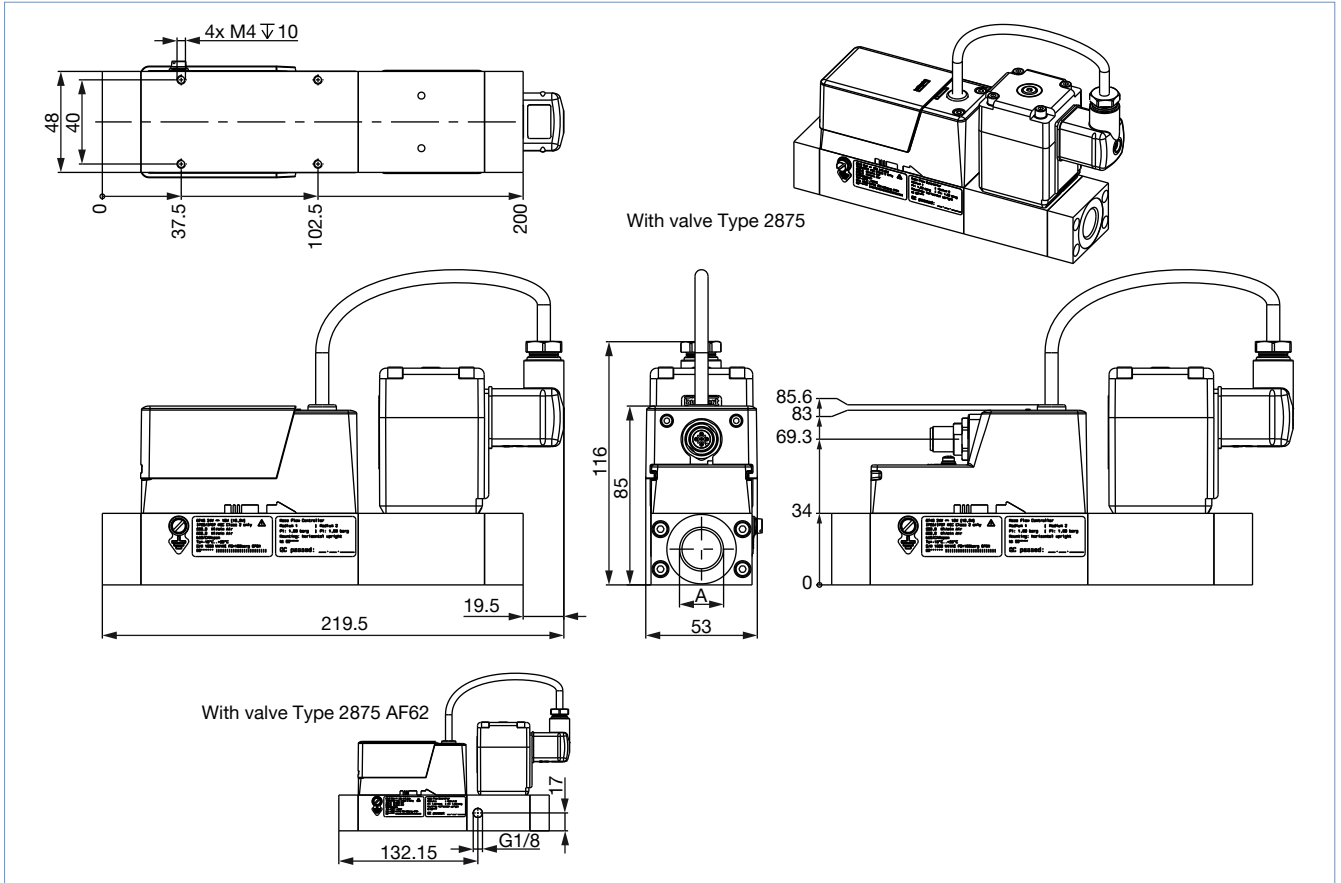

MFC with valve Type 2836

Variant with base block 00 or A1 for small nominal flow rates

Note:

Dimensions in mm

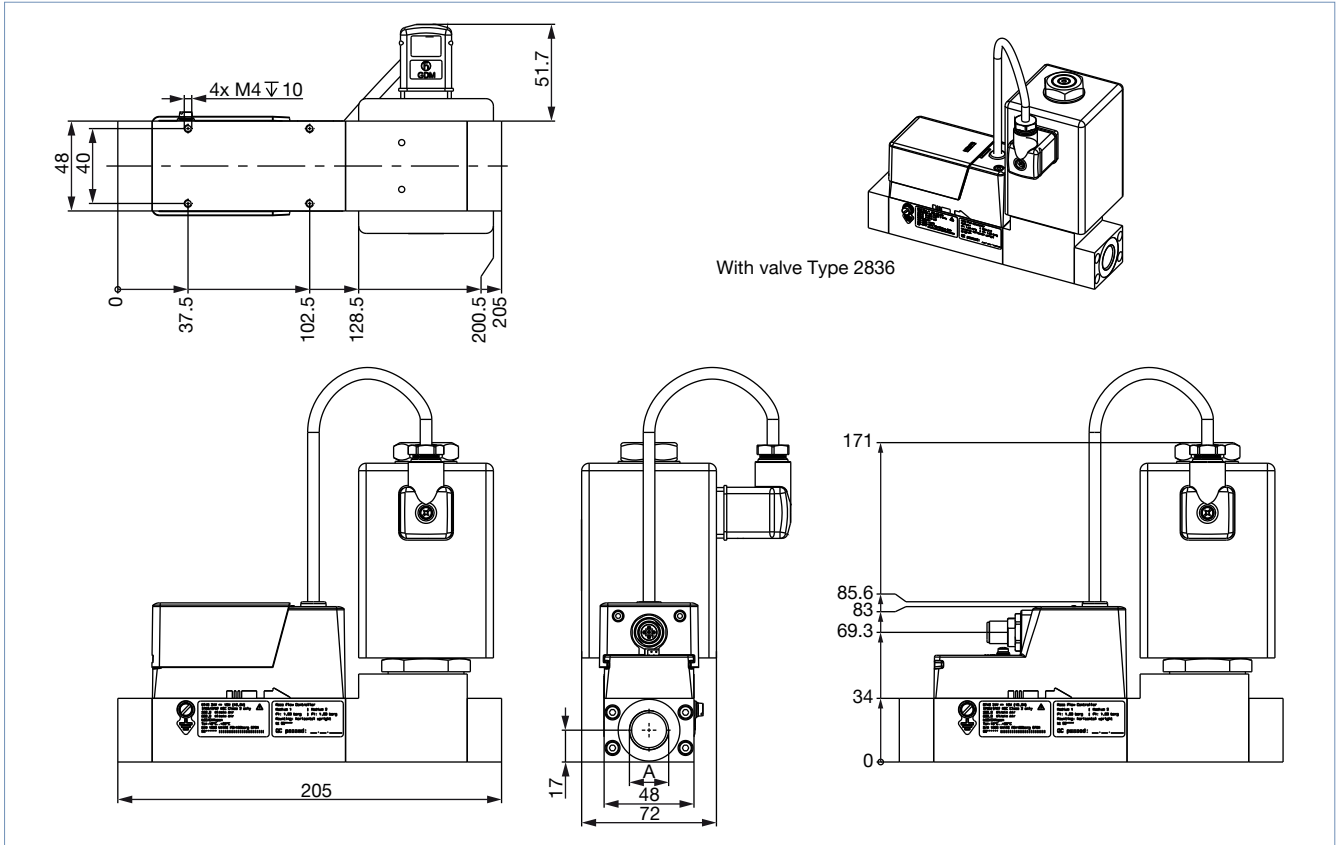

Variant with base block A2 for large nominal flow rates

**Note:**  
Dimensions in mm

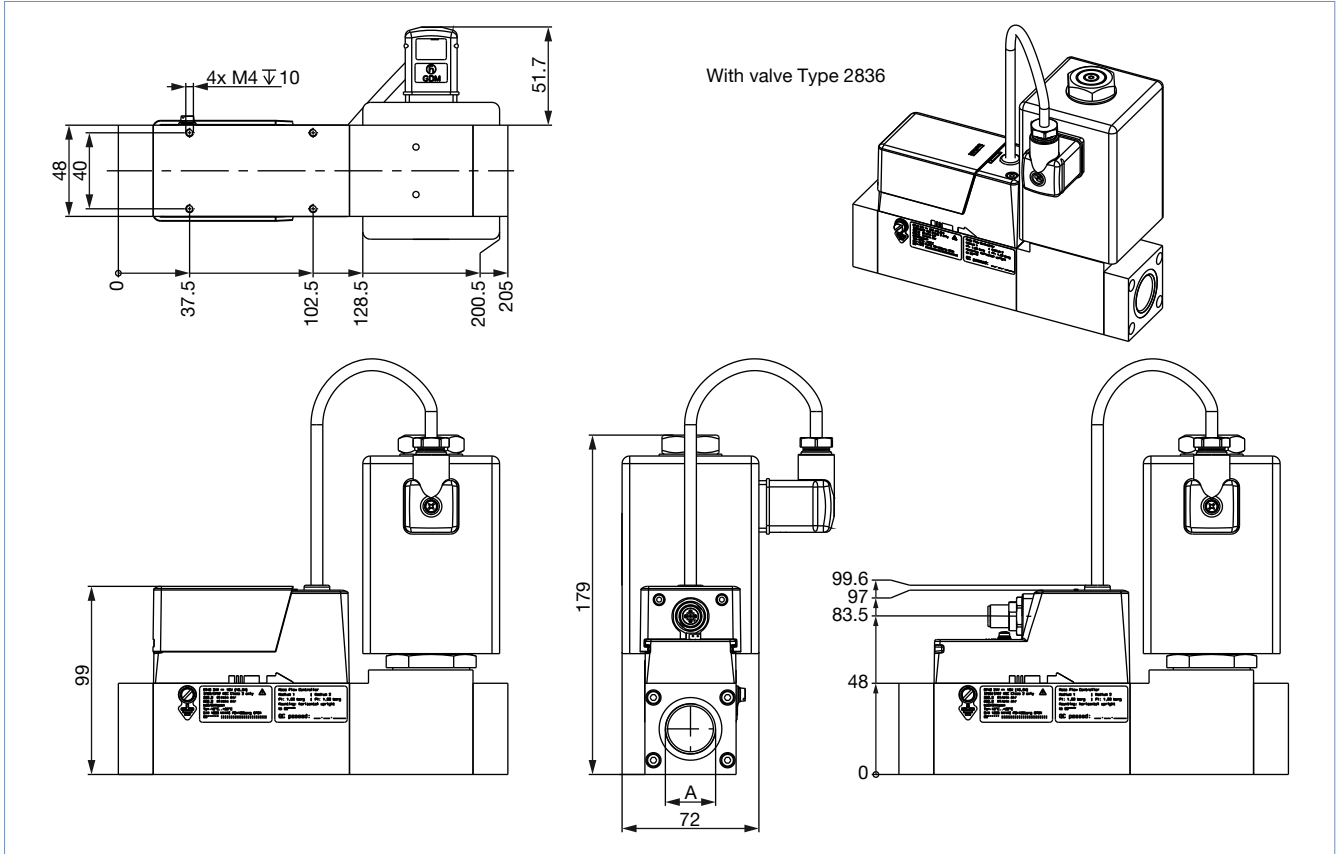

Variant with base block A3 for very large nominal flow rates

Note:

- From a nominal flow rate  $Q_N > 1500$  l/min onwards, the overall length increases by 30 mm.
- Dimensions in mm

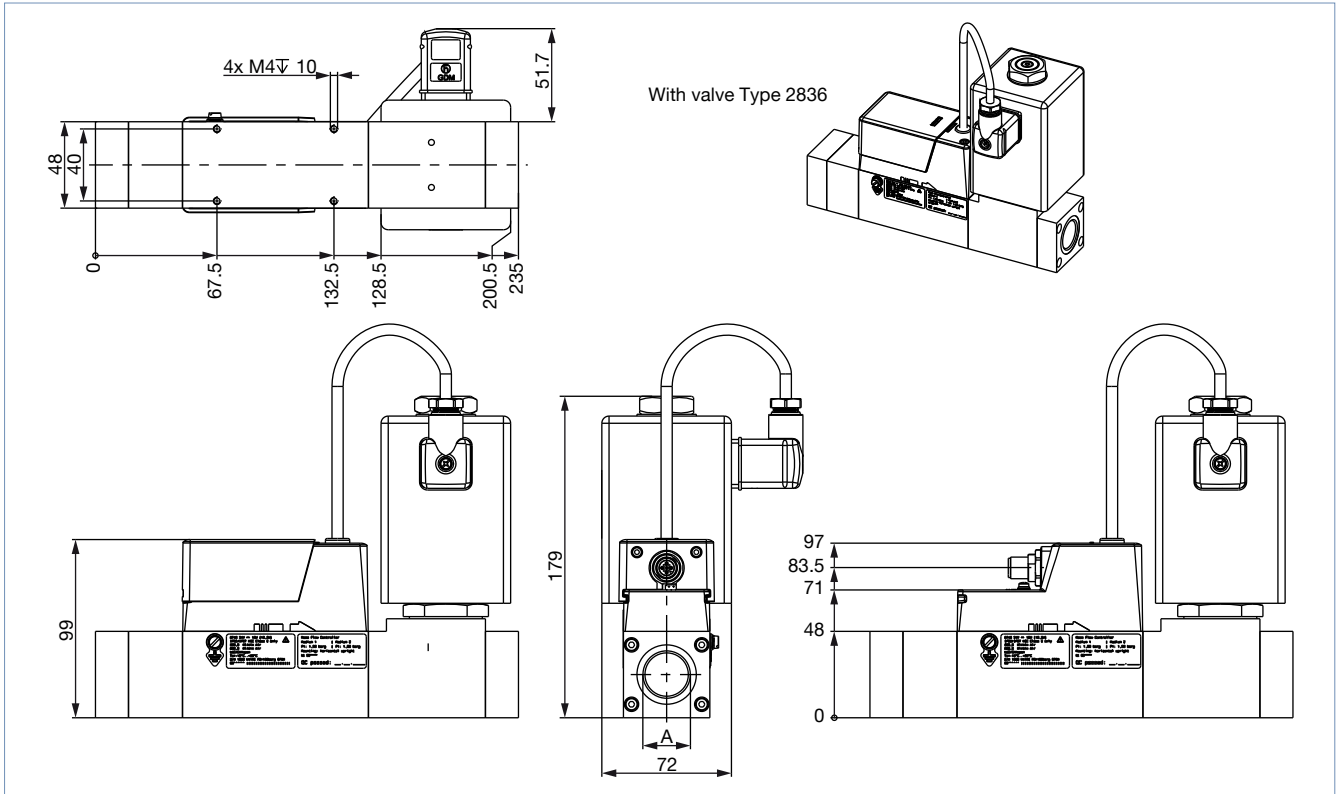

4.3. Variant with electromotive proportional valve and büS/CANopen interface

MFC with valve Type 3280

Variant with base block 00 or A1 for small nominal flow rates

**Note:**

Dimensions in mm

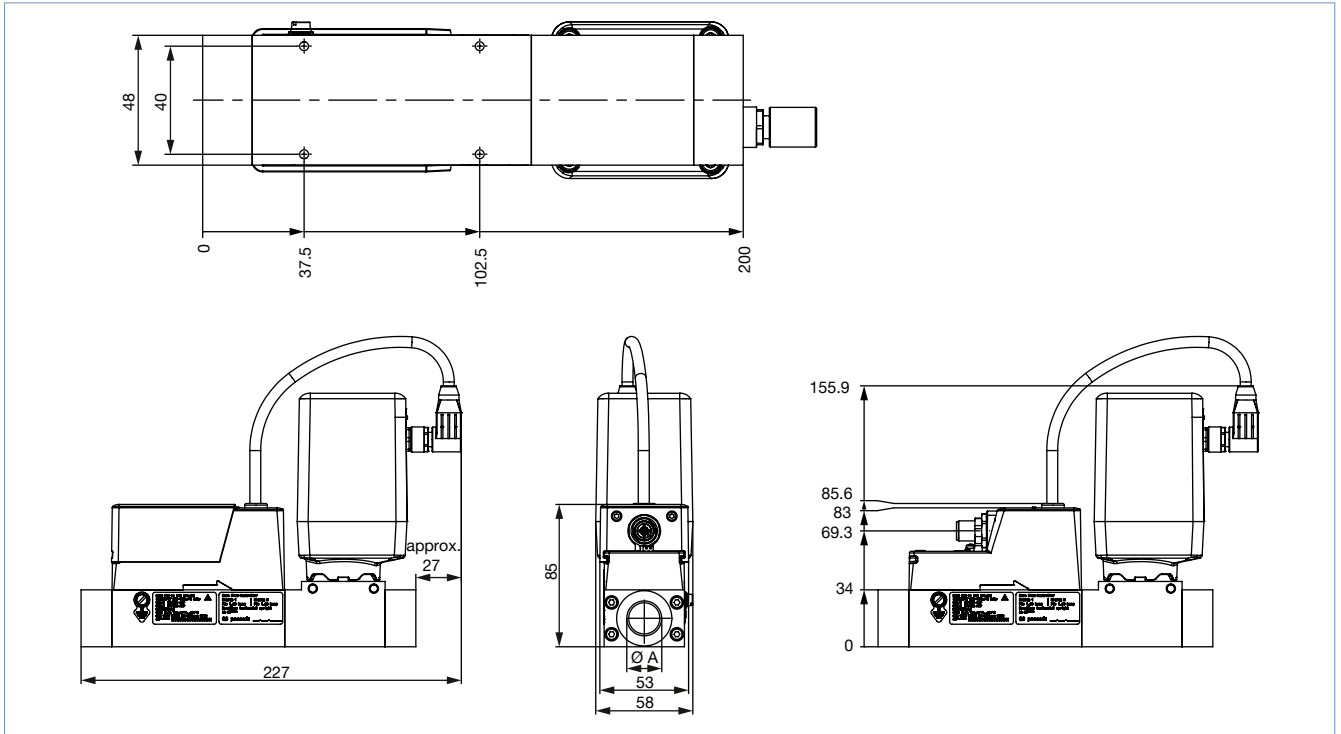

Variant with base block A2 for large nominal flow rates

**Note:**

Dimensions in mm

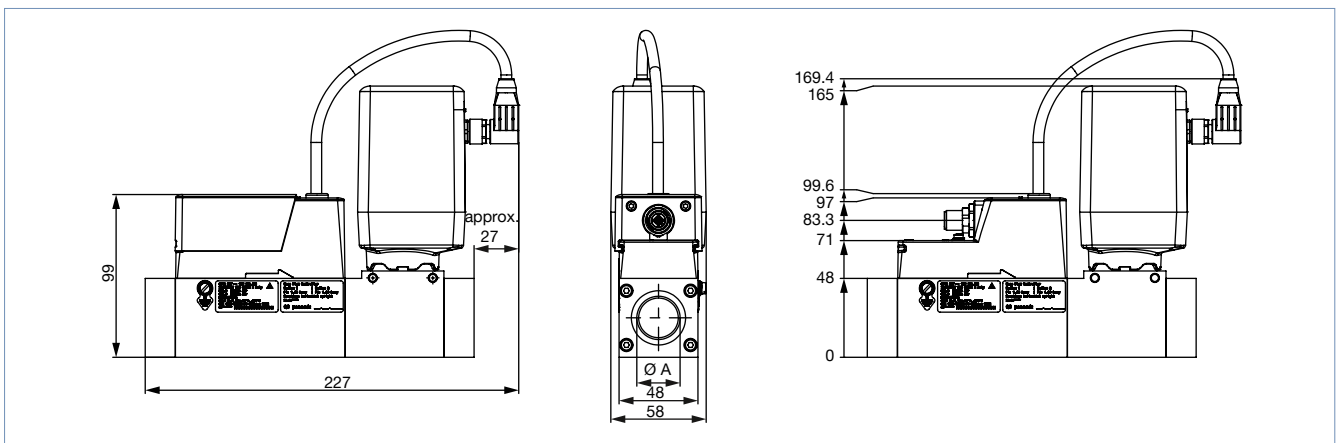

DTS 1000241027 EN Version: X Status: RL (released | freigegeben | valide) printed: 29.04.2024

**Variant with base block A3 for very large nominal flow rates**

**Note:**

- From a nominal flow rate  $Q_N > 1500$  l/min onwards, the overall length increases by 30 mm.
- Dimensions in mm

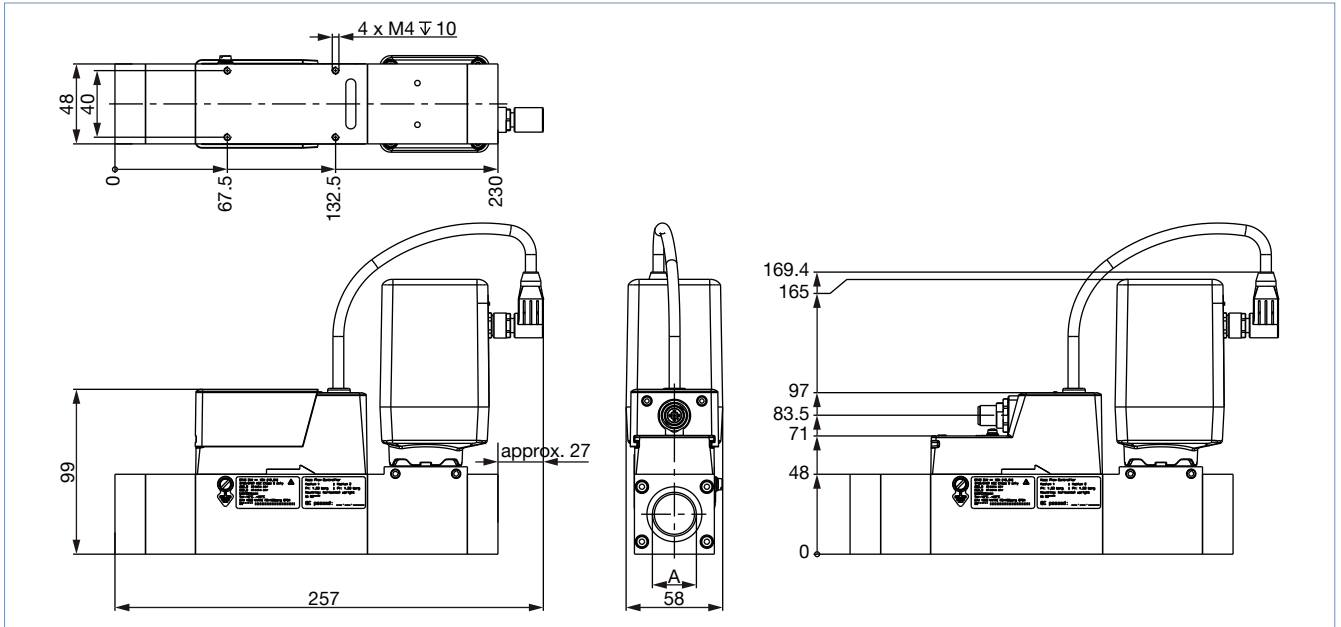

**MFC with valve Type 3285 (DN 12 and DN 15)**

**Variant with base block A2 for large nominal flow rates**

**Note:**

Dimensions in mm

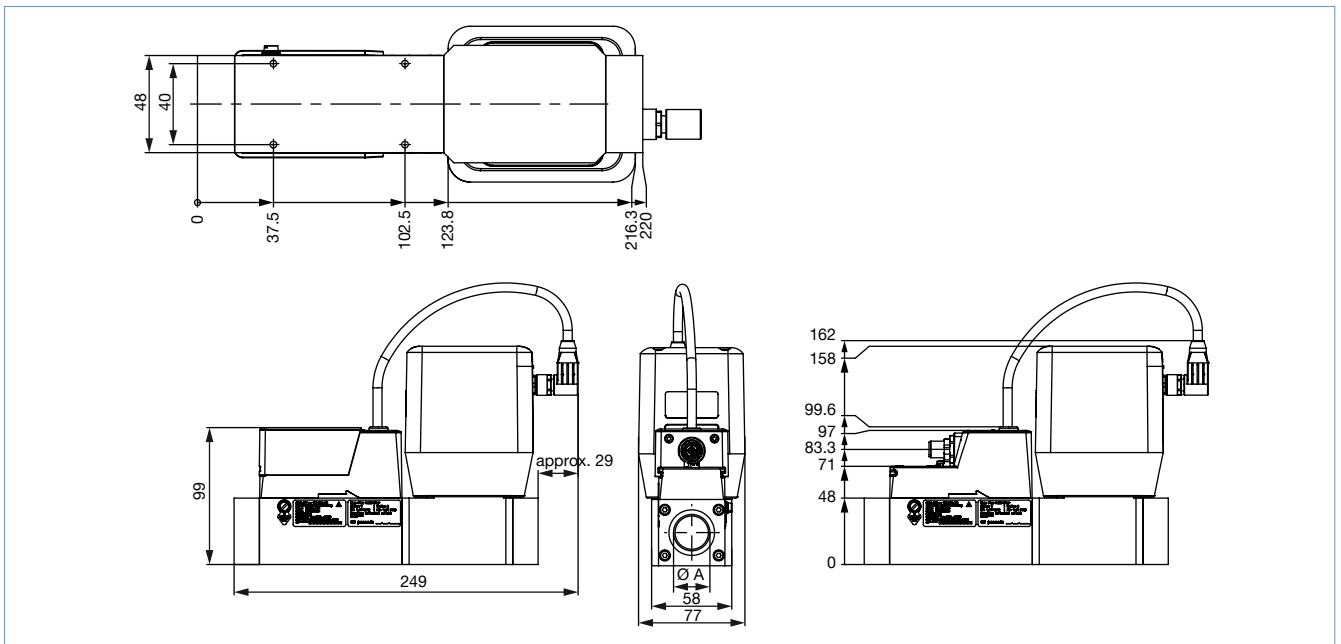

DTS 1000241027 EN Version: X Status: RL (released | freigegeben | valide) printed: 29.04.2024

**Variant with base block A3 for very large nominal flow rates**

**Note:**

- From a nominal flow rate  $Q_N > 1500$  l/min onwards, the overall length increases by 30 mm.
- Dimensions in mm

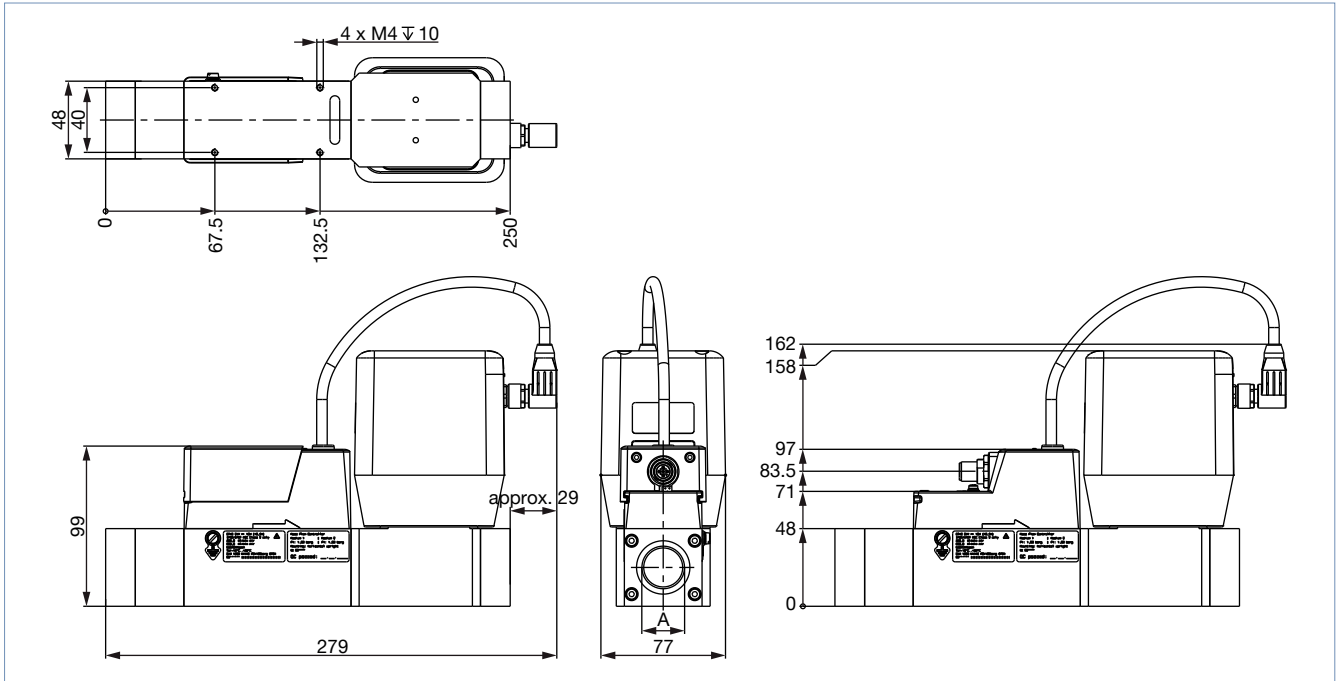

**MFC with valve Type 3285 (DN 20 and DN 25)**

**Variant with base block A2 for large nominal flow rates**

**Note:**

Dimensions in mm

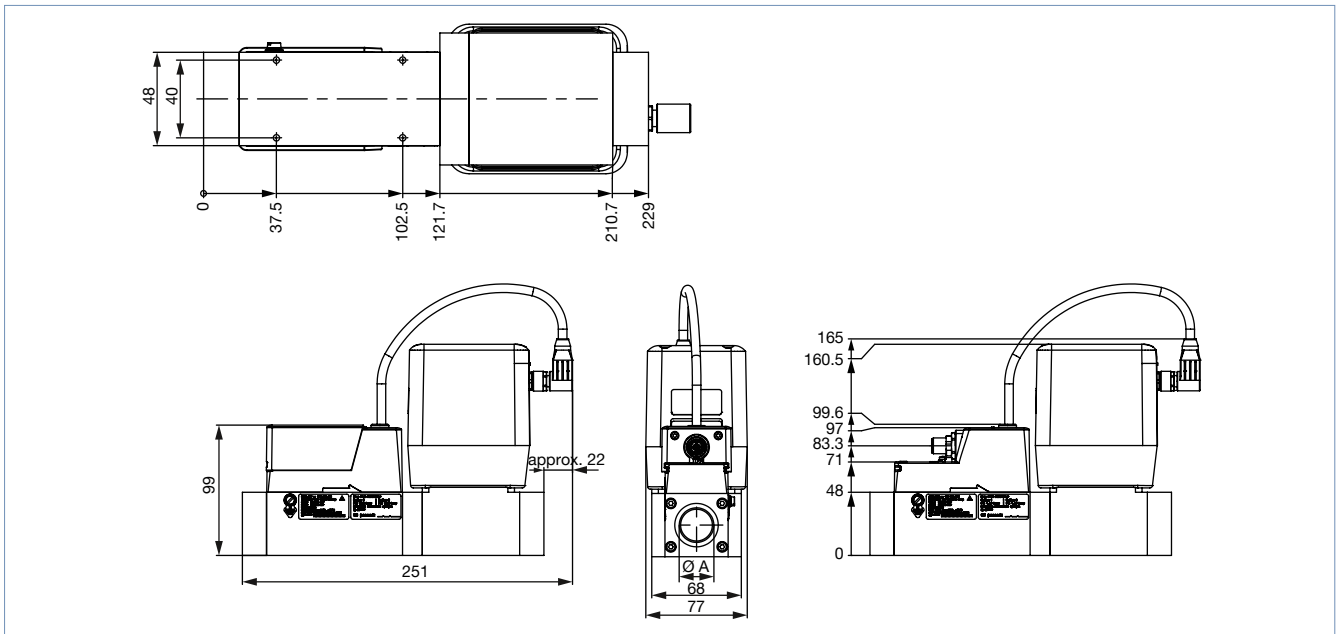

DTS 1000241027 EN Version: X Status: RL (released | freigegeben | validé) printed: 29.04.2024

**Variant with base block A3 for very large nominal flow rates**

**Note:**

- From a nominal flow rate  $Q_N > 1500$  l/min onwards, the overall length increases by 30 mm.
- Dimensions in mm

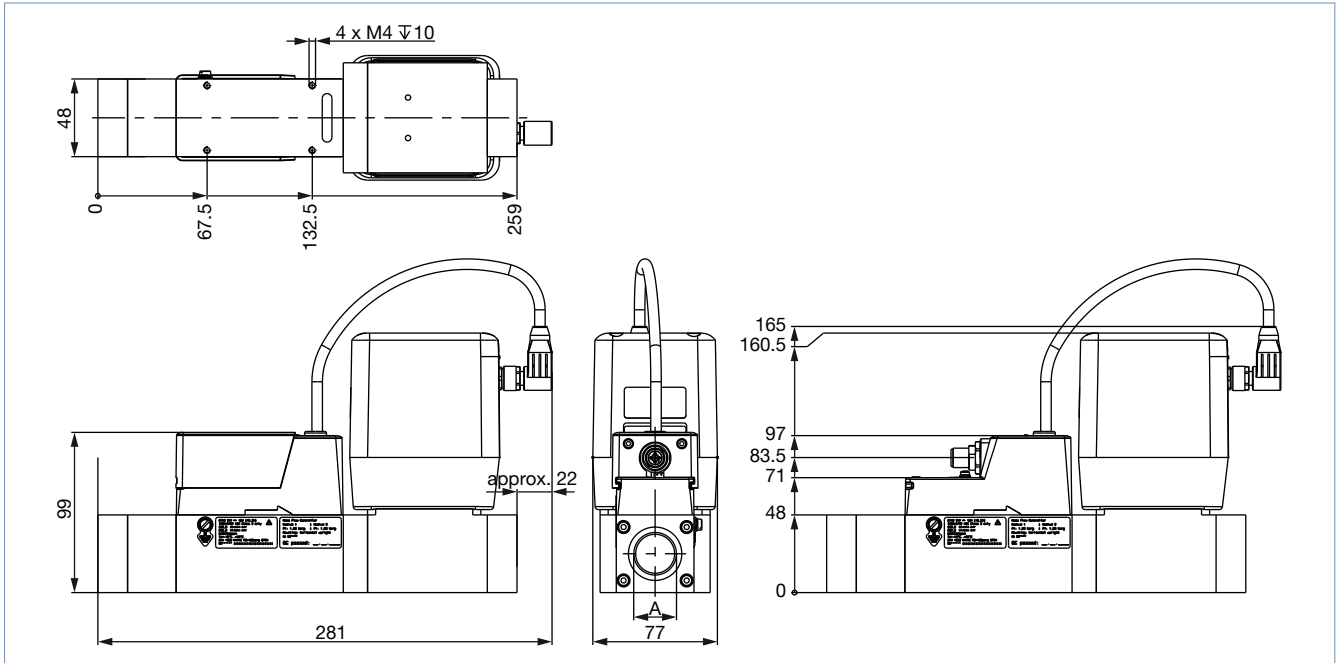

**4.4. MFM variant with büS/CANopen interface**

**Variant with base block 00 or A1 for small nominal flow rates**

**Note:**

Dimensions in mm

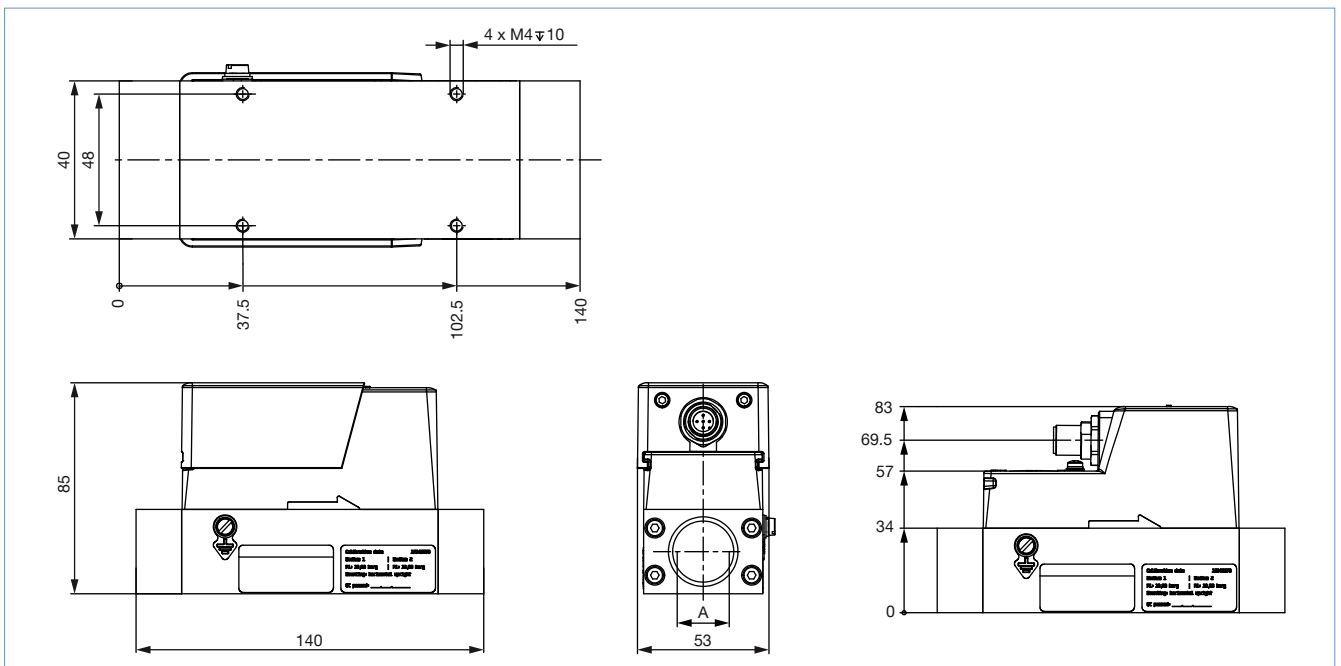

DTS 1000241027 EN Version: X Status: RL (released | freigegeben | valide) printed: 29.04.2024



**Variant with base block A2 for large nominal flow rates**

**Note:**  
Dimensions in mm

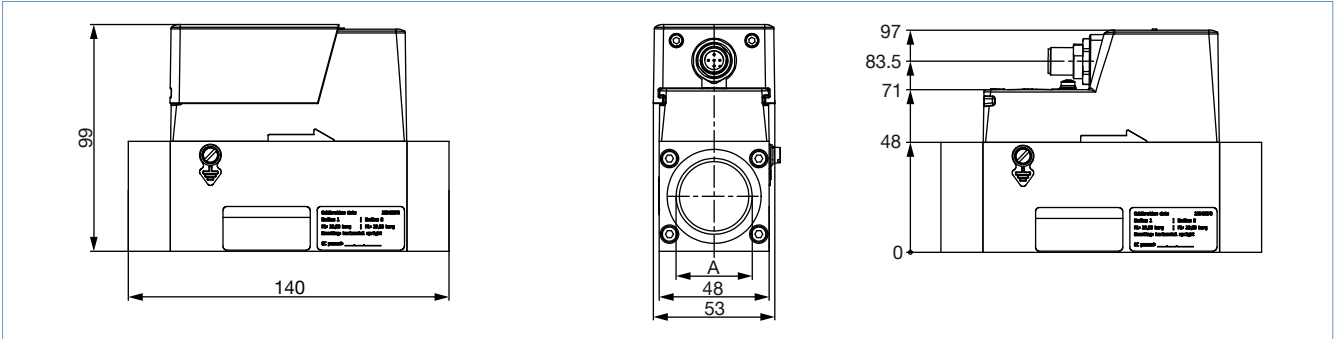

**Variant with base block A3 for very large nominal flow rates**

**Note:**

- From a nominal flow rate  $Q_N > 1500$  l/min onwards, the overall length increases by 30 mm.
- Dimensions in mm

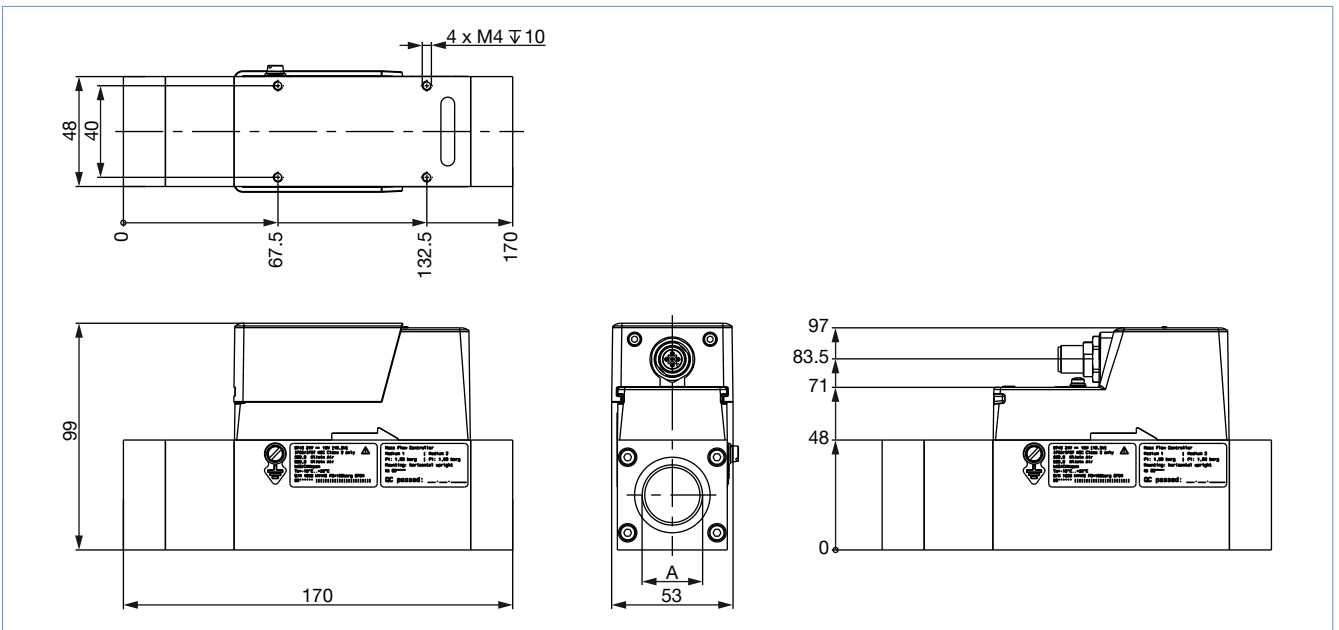

DTS 1000241027 EN Version: X Status: RL (released | freigegeben | valide) printed: 29.04.2024

4.5. Variant with electromagnetic proportional valve and analogue or PROFIBUS DPV1 interface

MFC with valve Type 2873

Variant with base block 00 or A1 for small nominal flow rates

Note:

Dimensions in mm

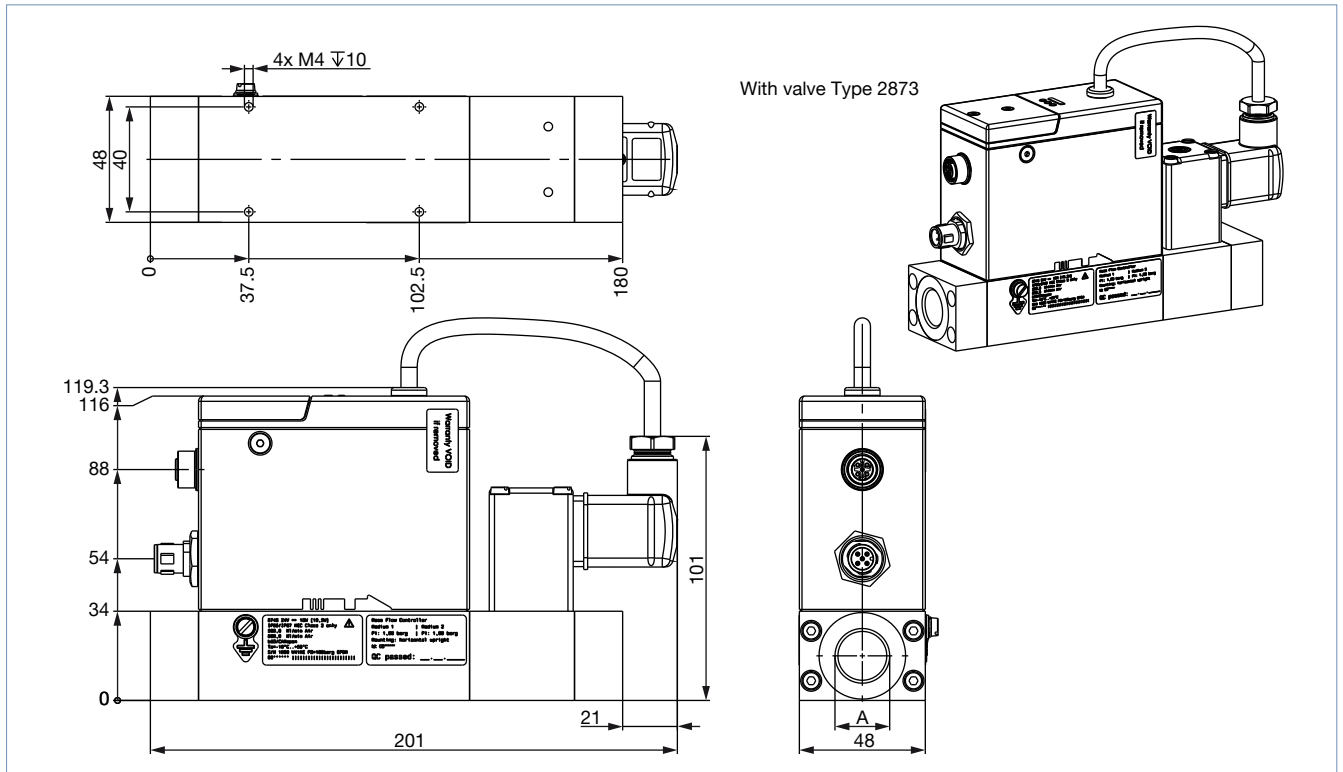

**MFC with valve Type 2875**

Variant with base block 00 or A1 for small nominal flow rates

**Note:**

Dimensions in mm

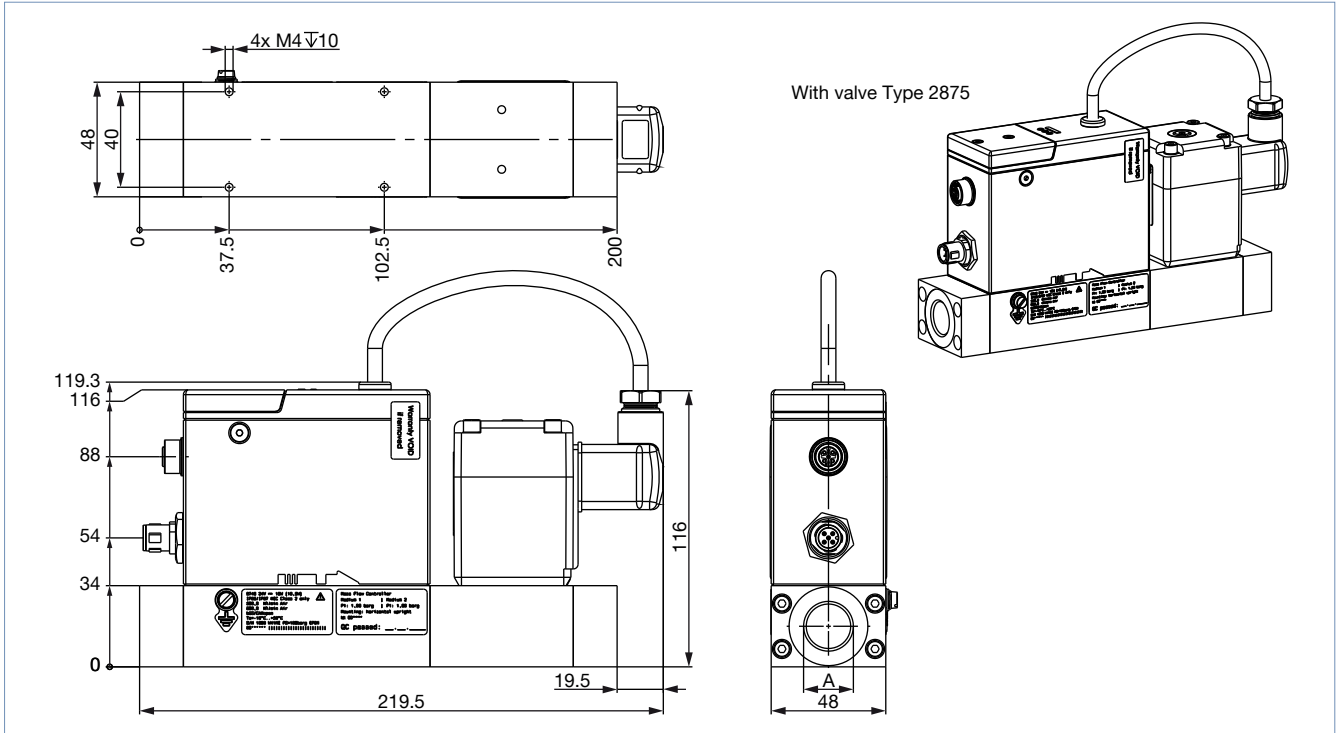

**MFC with valve Type 2836**

Variant with base block 00 or A1 for small nominal flow rates

**Note:**

Dimensions in mm

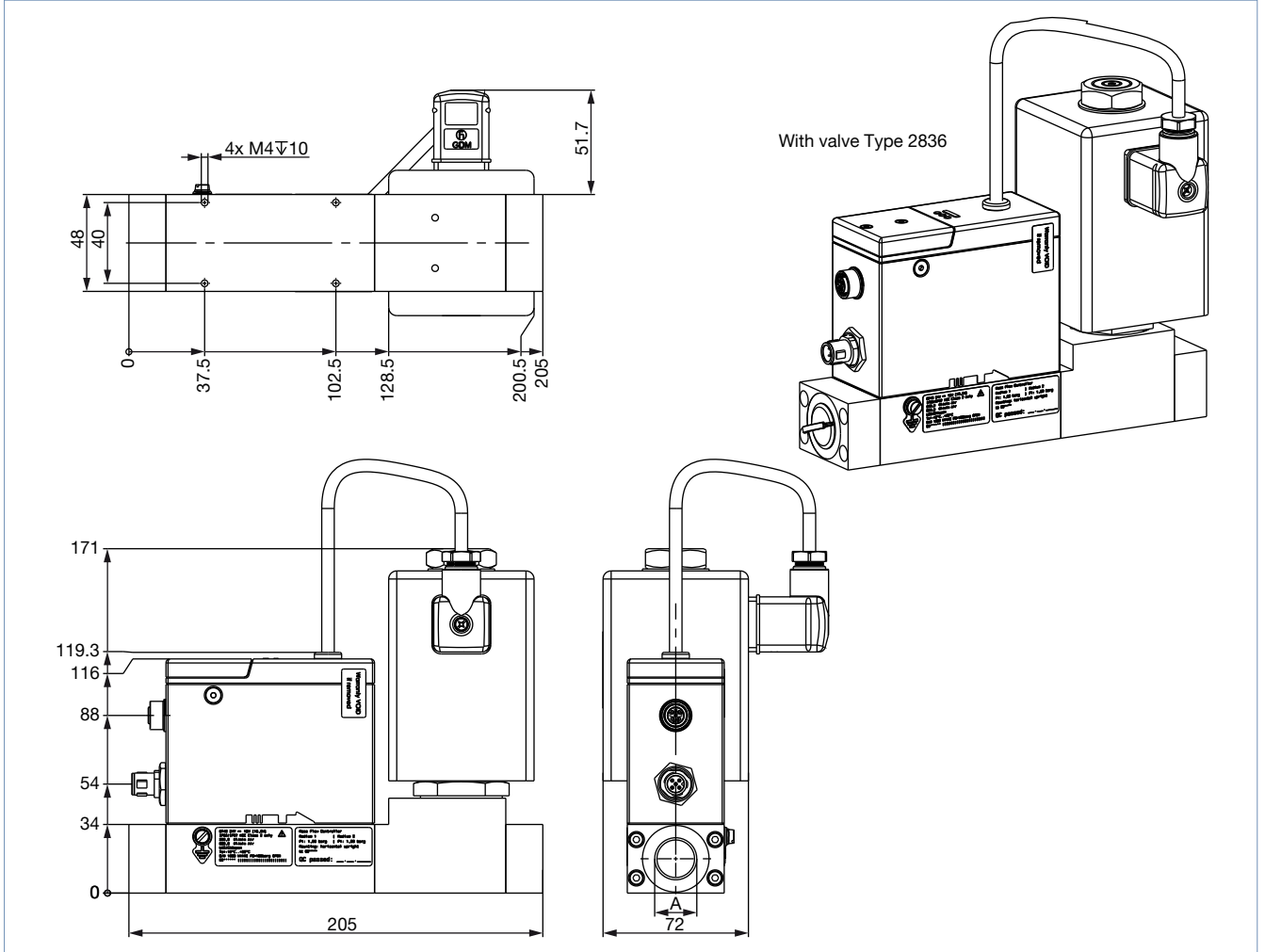

Variant with base block A2 for large nominal flow rates

**Note:**  
Dimensions in mm

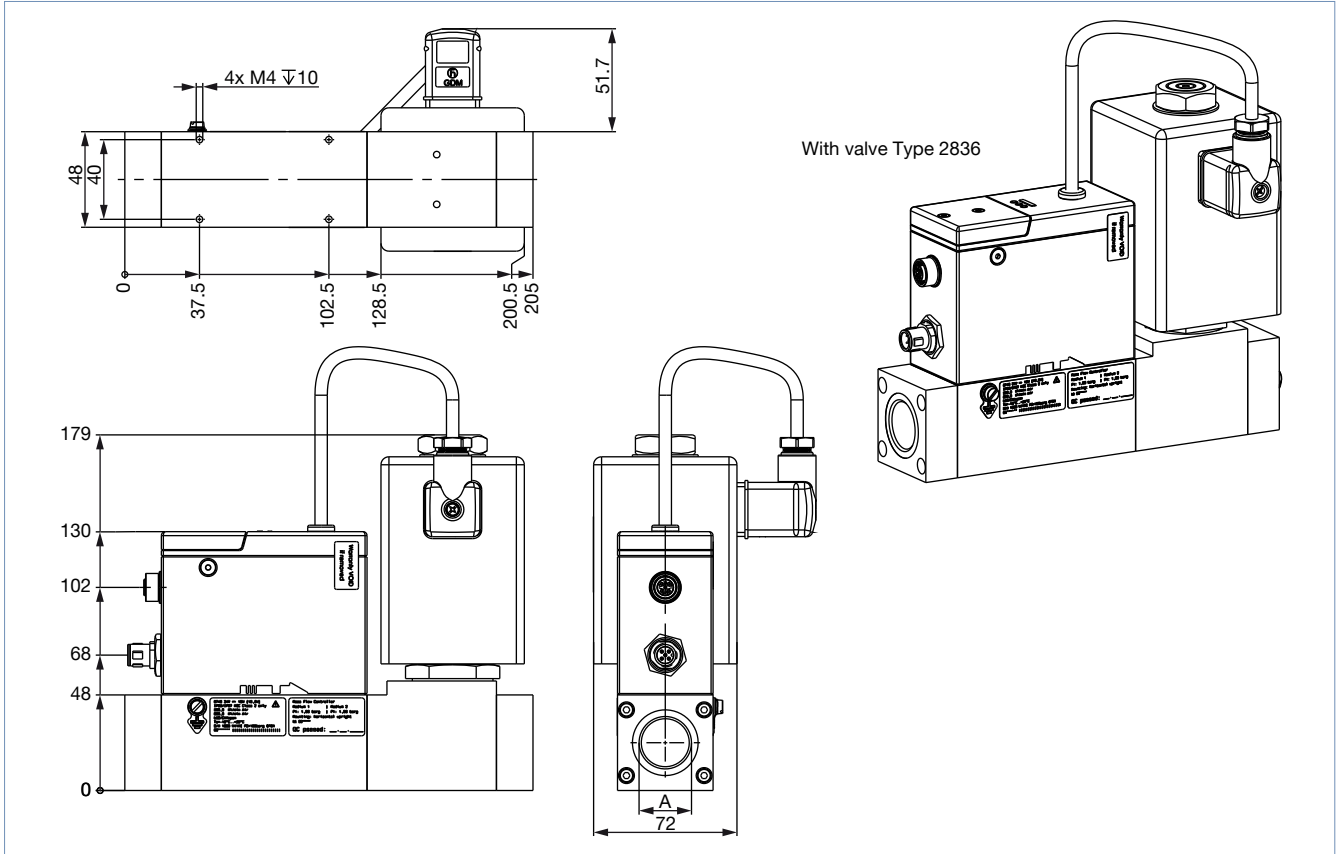

DTS 1000241027 EN Version: X Status: RL (released | freigegeben | valide) printed: 29.04.2024

**Variant with base block A3 for very large nominal flow rates**

**Note:**

- From a nominal flow rate  $Q_N > 1500$  l/min onwards, the overall length increases by 30 mm.
- Dimensions in mm

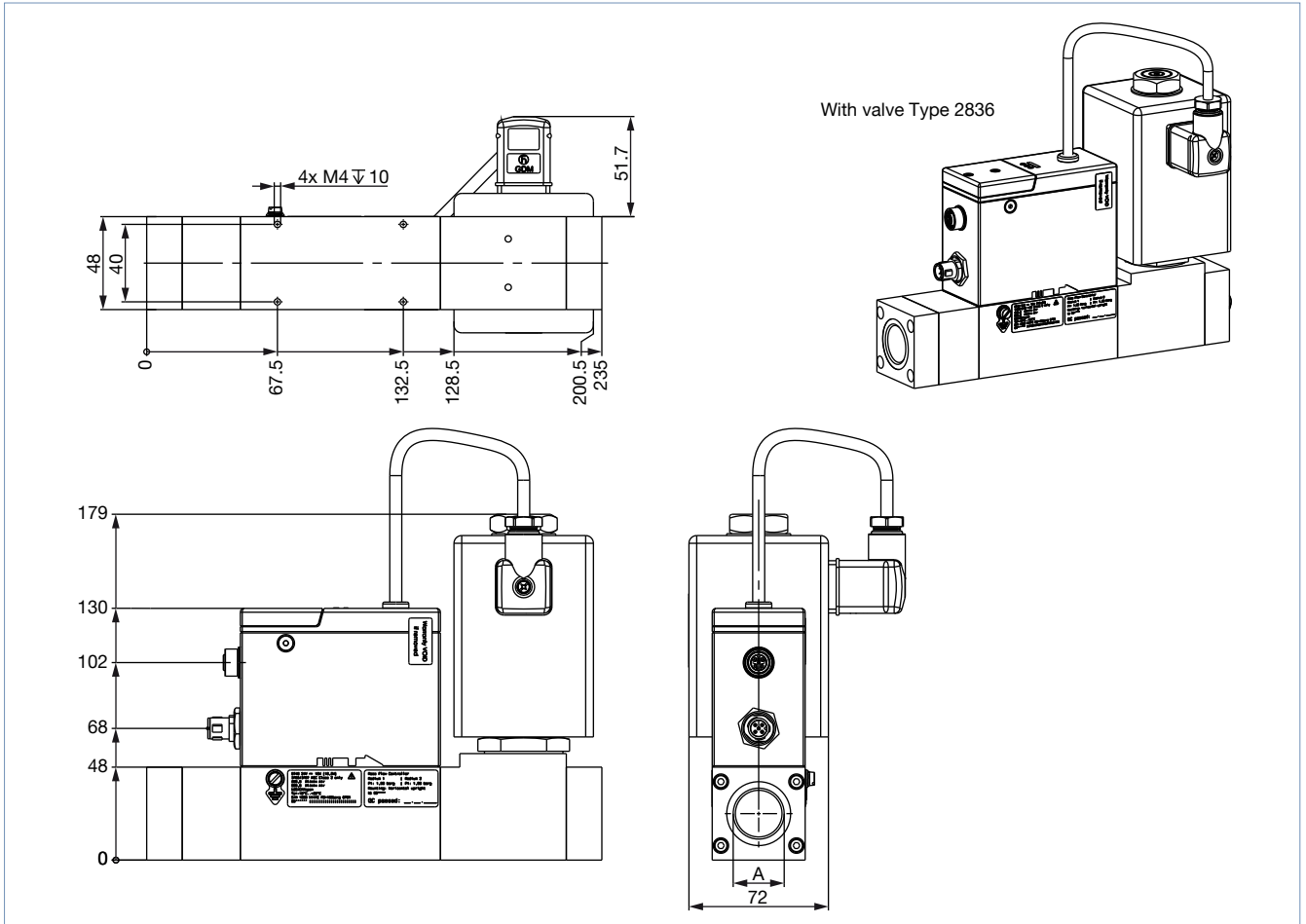

DTS 1000241027 EN Version: X Status: RL (released | freigegeben | validé) printed: 29.04.2024

4.6. Variant with electromotive proportional valve and analogue or PROFIBUS DPV1 interface

MFC with valve Type 3280

Variant with base block 00 or A1 for small nominal flow rates

Note:

Dimensions in mm

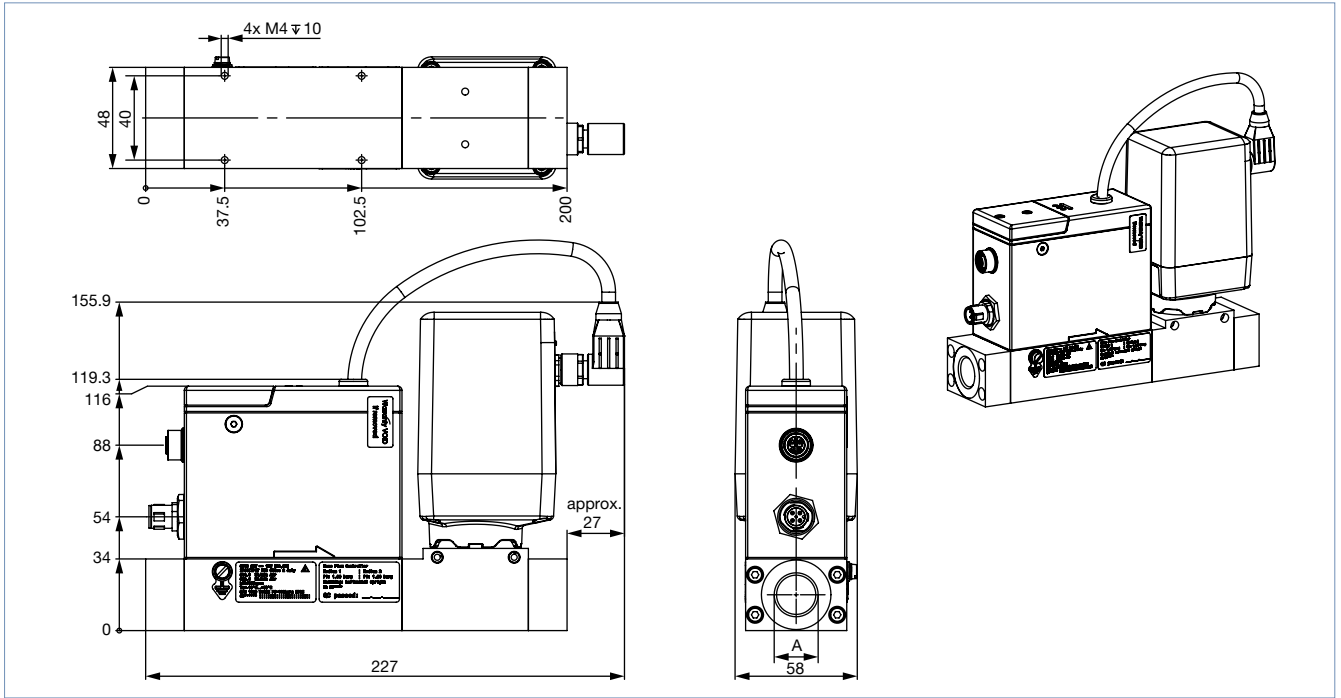

Variant with base block A2 for large nominal flow rates

**Note:**  
Dimensions in mm

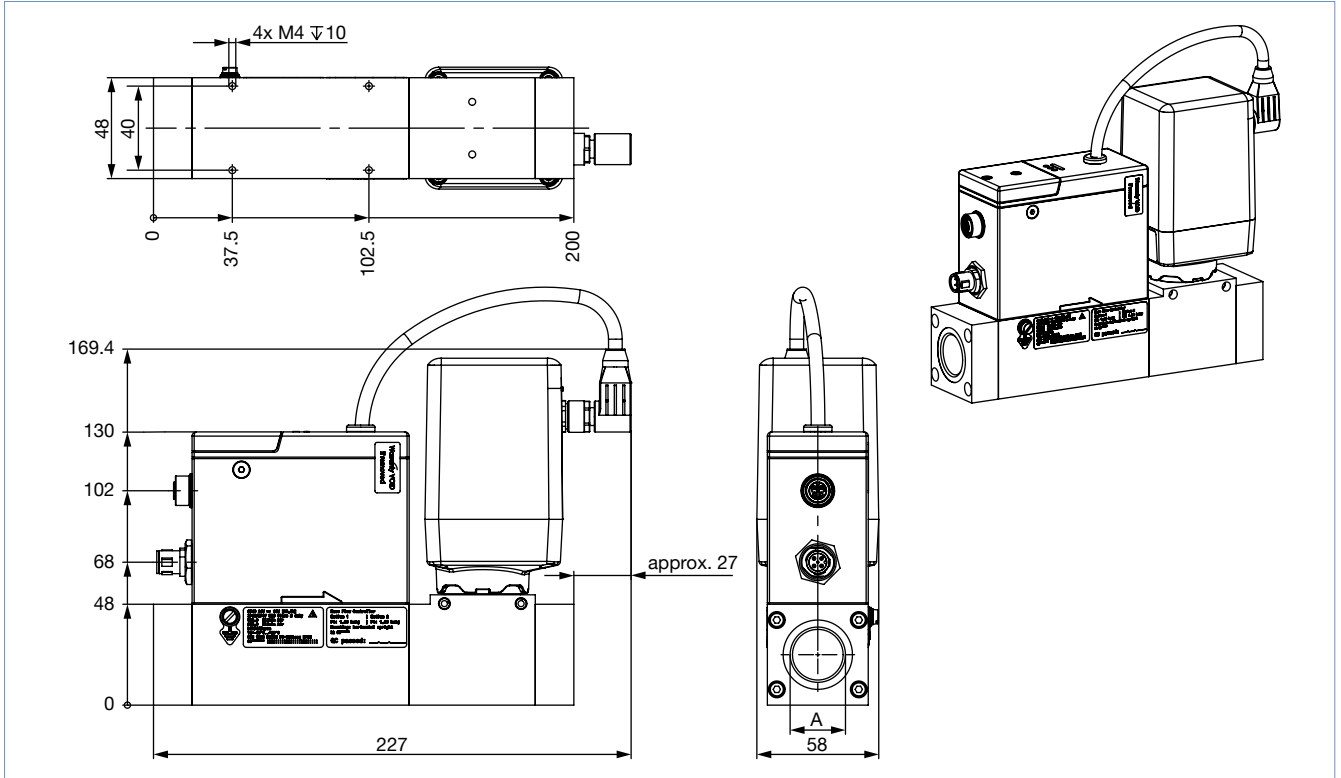

DTS 1000241027 EN Version: X Status: RL (released | freigegeben | validé) printed: 29.04.2024



**Variant with base block A3 for very large nominal flow rates**

**Note:**

- From a nominal flow rate  $Q_N > 1500$  l/min onwards, the overall length increases by 30 mm.
- Dimensions in mm

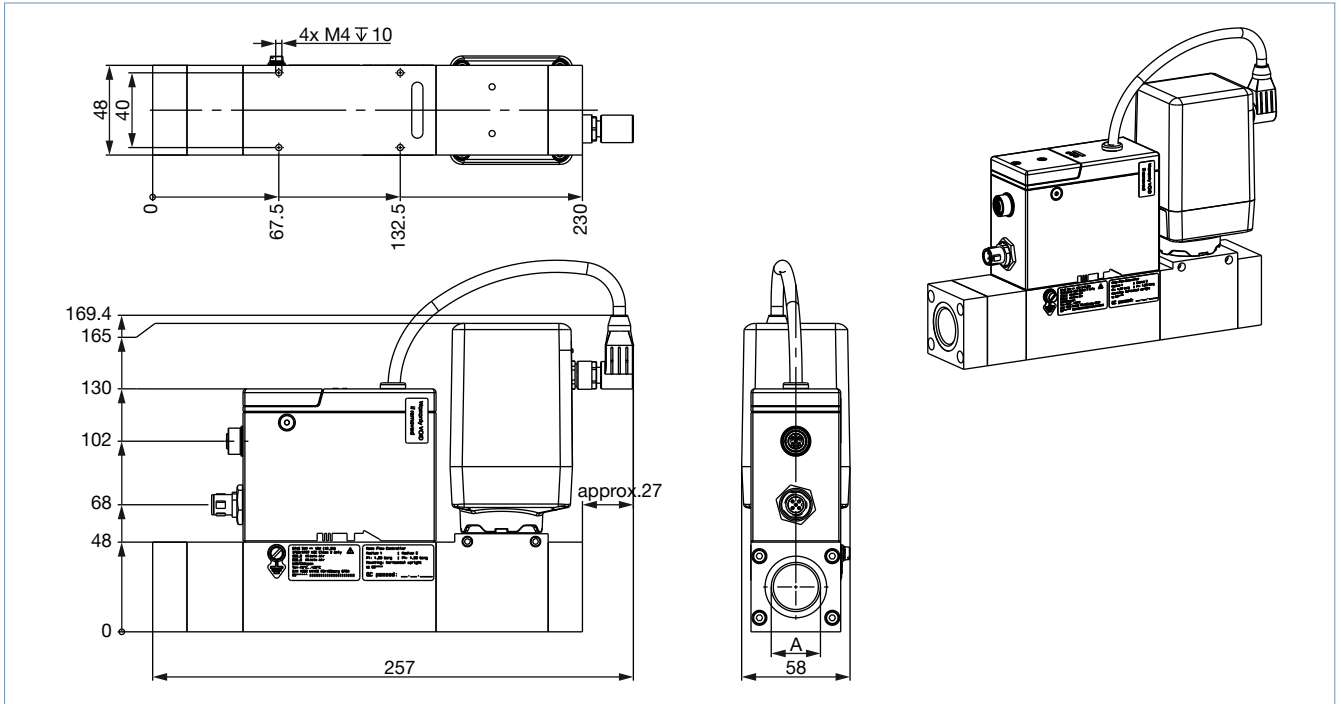

**MFC with valve Type 3285 (DN 12 and DN 15)**

**Variant with base block A2 for large nominal flow rates**

**Note:**

Dimensions in mm

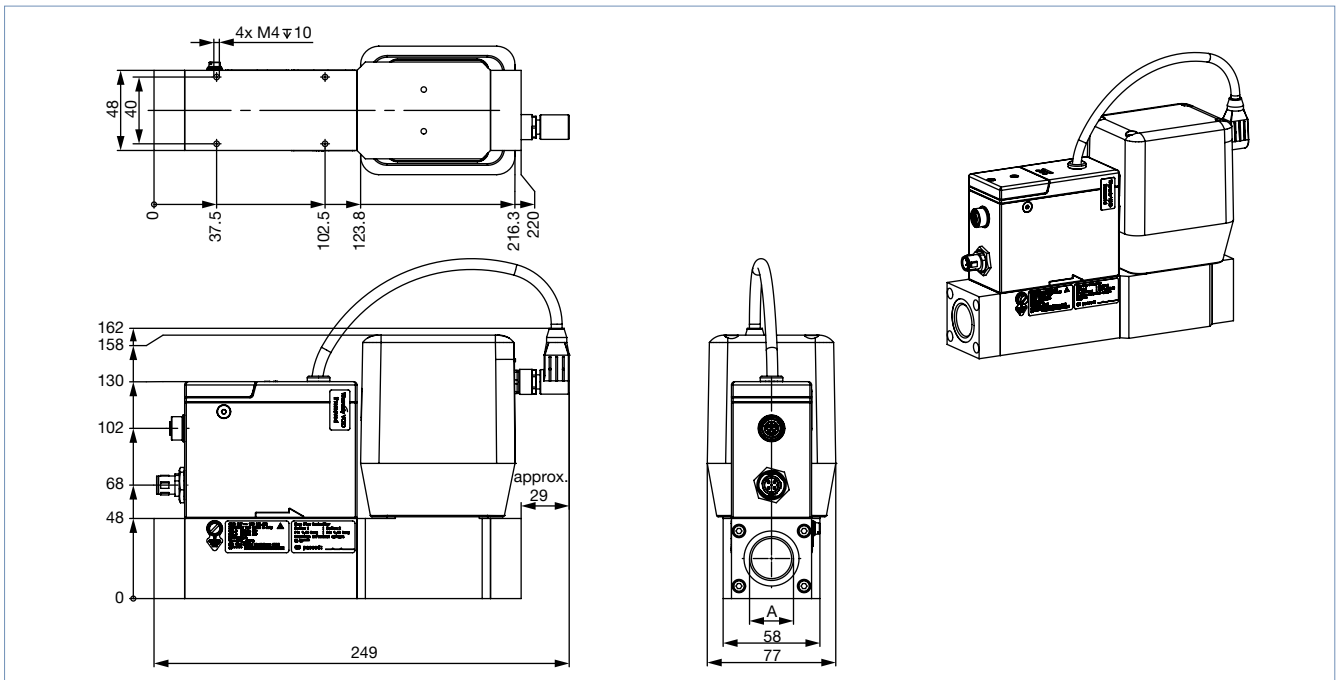

DTS 1000241027 EN Version: X Status: RL (released | freigegeben | valide) printed: 29.04.2024

**Variant with base block A3 for very large nominal flow rates**

**Note:**

- From a nominal flow rate  $Q_N > 1500$  l/min onwards, the overall length increases by 30 mm.
- Dimensions in mm

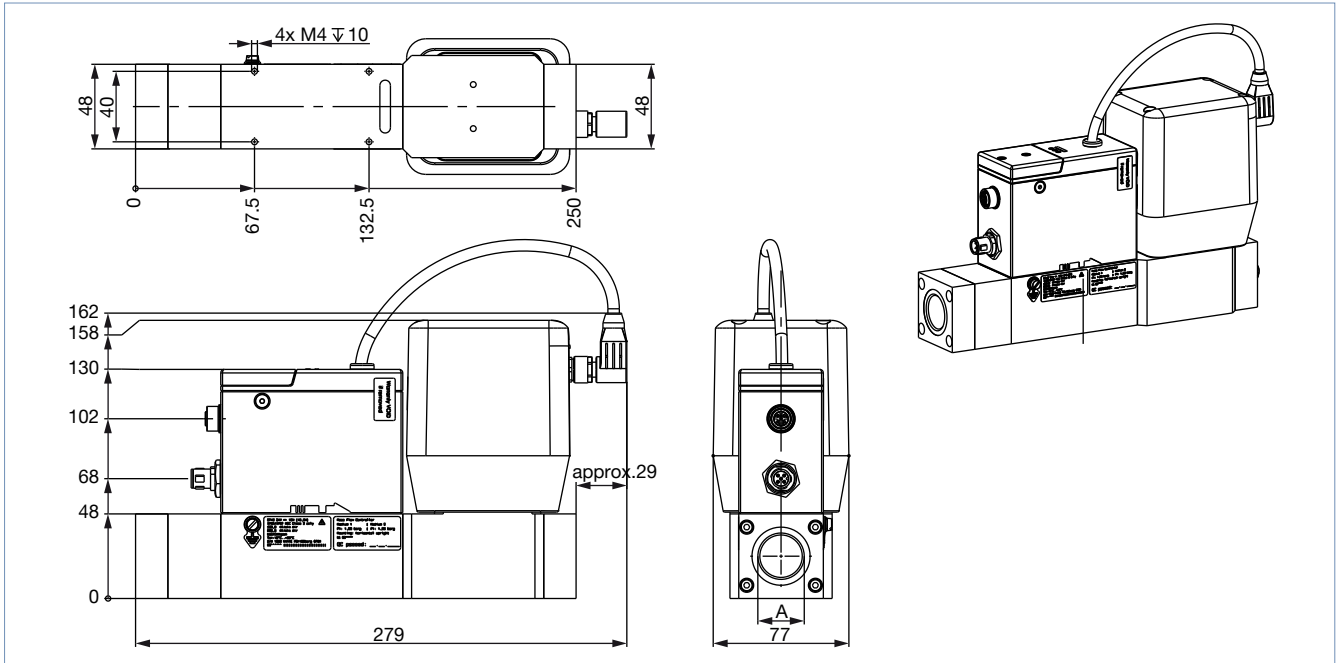

**MFC with valve Type 3285 (DN 20 and DN 25)**

**Variant with base block A2 for large nominal flow rates**

**Note:**

Dimensions in mm

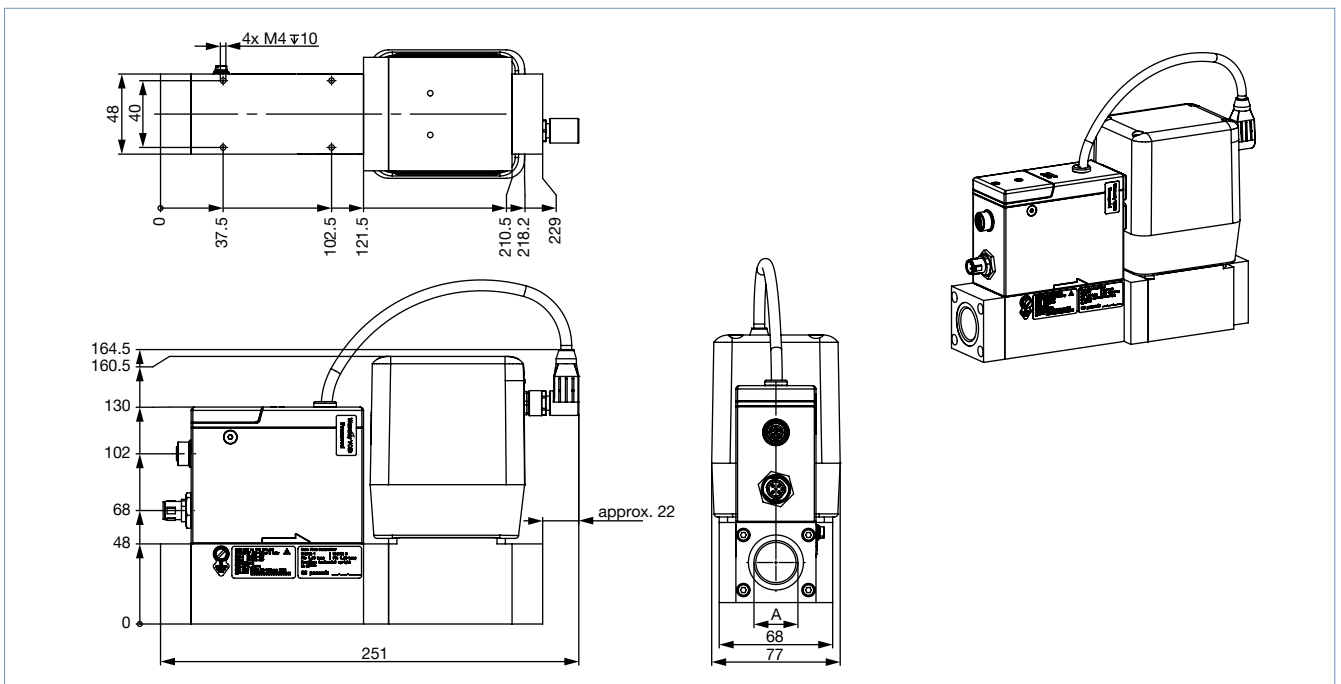

DTS 1000241027 EN Version: X Status: RL (released | freigegeben | valide) printed: 29.04.2024

**Variant with base block A3 for very large nominal flow rates**

**Note:**

- From a nominal flow rate  $Q_N > 1500$  l/min onwards, the overall length increases by 30 mm.
- Dimensions in mm

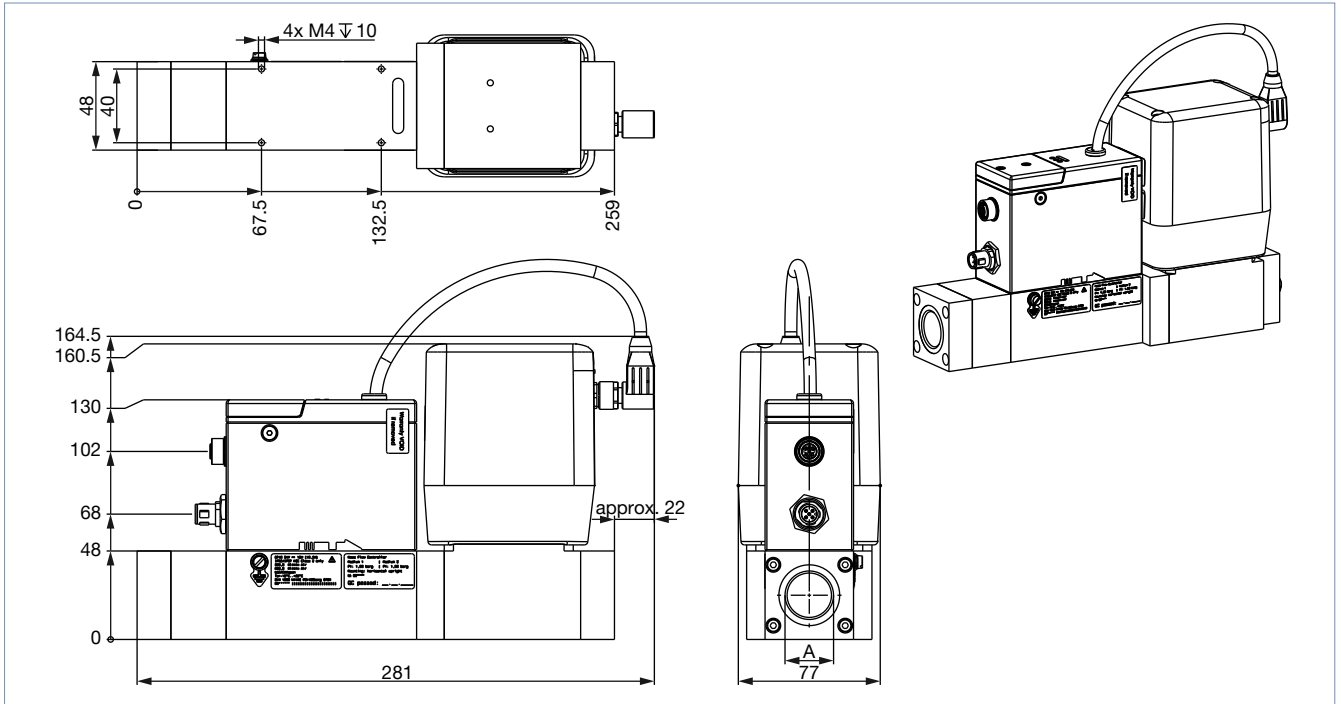

**4.7. MFM variant with analogue or PROFIBUS DPV1 interface**

**Variant with base block 00 or A1 for small nominal flow rates**

**Note:**

Dimensions in mm

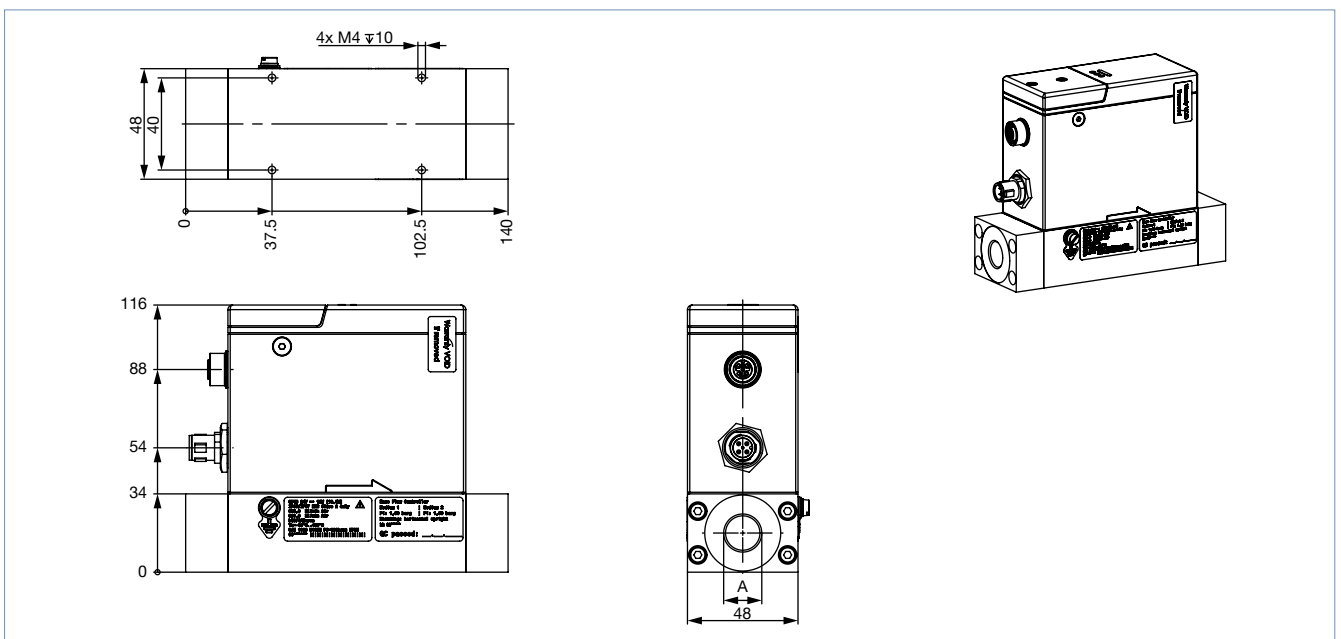

DTS 1000241027 EN Version: X Status: RL (released | freigegeben | valide) printed: 29.04.2024

**Variant with base block A2 for large nominal flow rates**

**Note:**  
Dimensions in mm

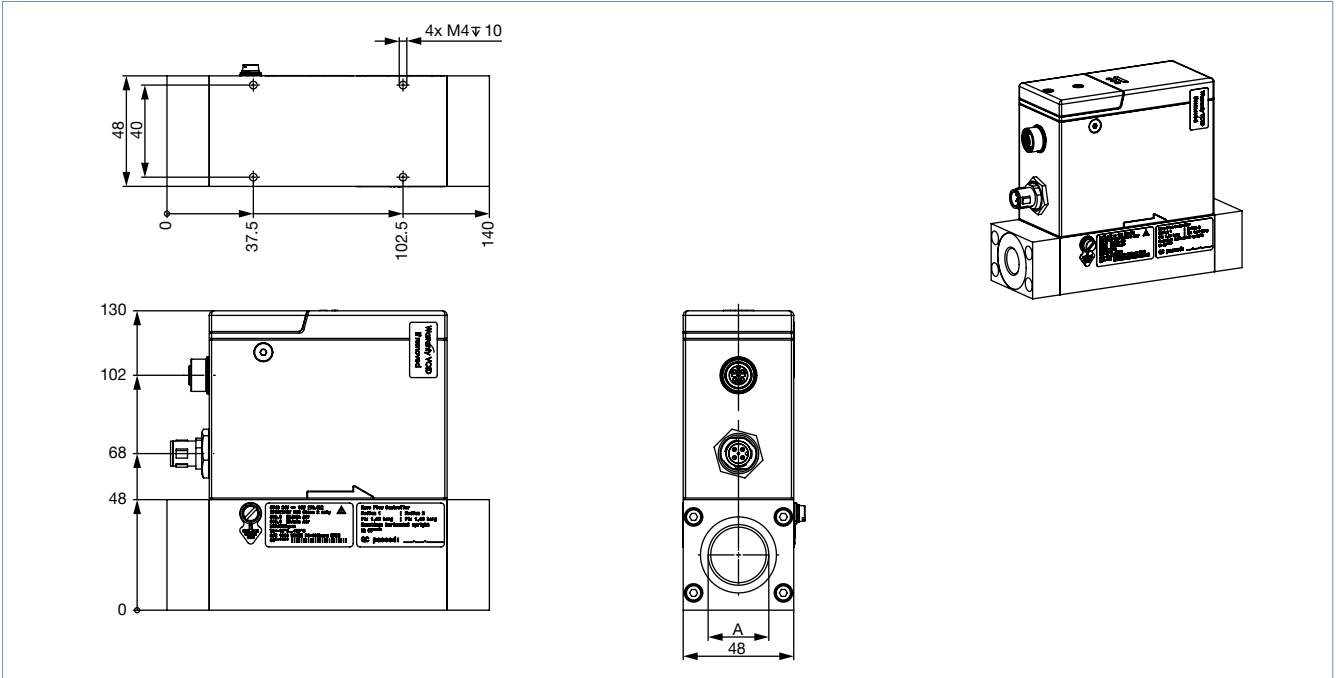

**Variant with base block A3 for very large nominal flow rates**

**Note:**

- From a nominal flow rate  $Q_N > 1500$  l/min onwards, the overall length increases by 30 mm.
- Dimensions in mm

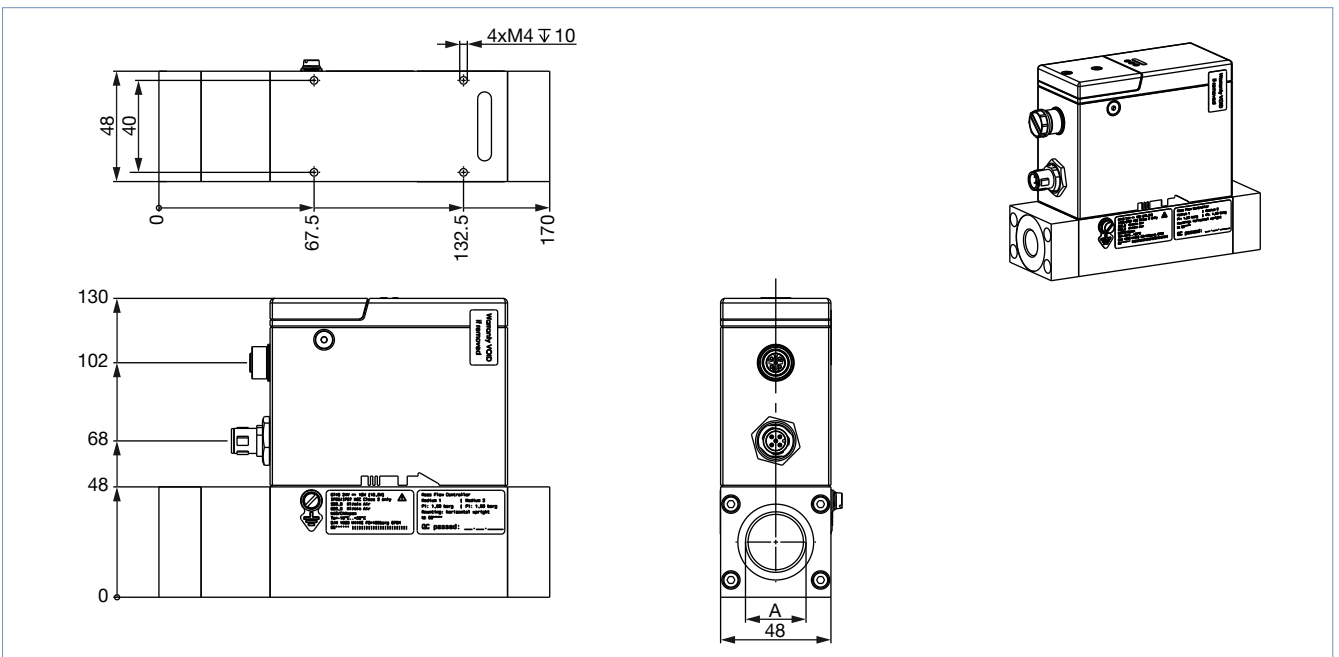

DTS 1000241027 EN Version: X Status: RL (released | freigegeben | validé) printed: 29.04.2024

4.8. Variant with Industrial Ethernet interface

Note:  
Dimensions in mm

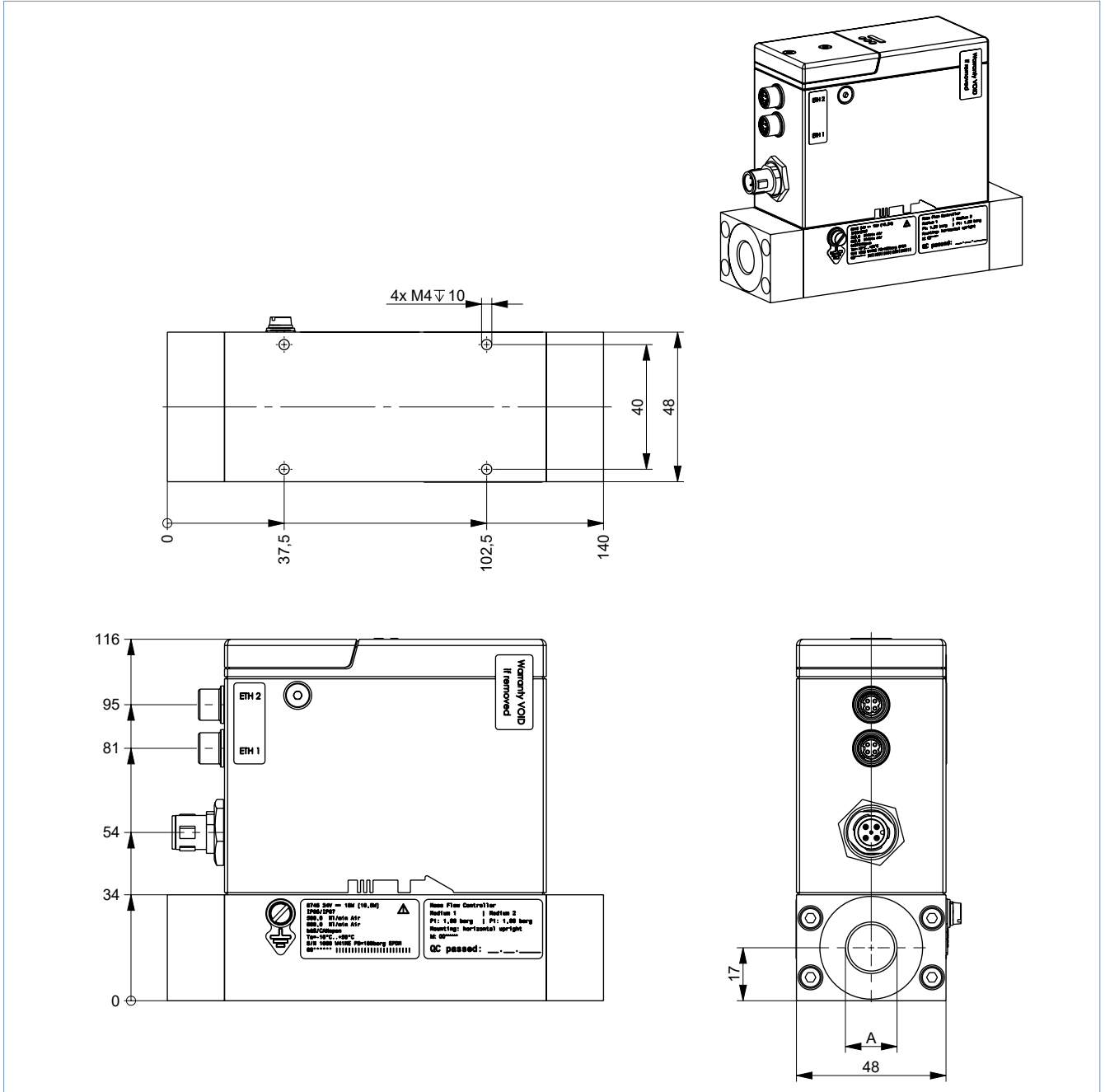

DTS 1000241027 EN Version: X Status: RL (released | freigegeben | valide) printed: 29.04.2024

## 5. Device/Process connections

### 5.1. bÜS/CANopen

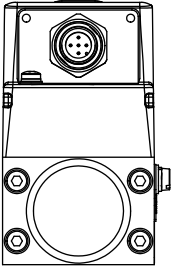

M12 plug, 5-pin (A-coded)	Pin	Assignment
	1	Shielding
	2	24 V
	3	DGND
	4	CAN_H
	5	CAN_L

### 5.2. Industrial Ethernet

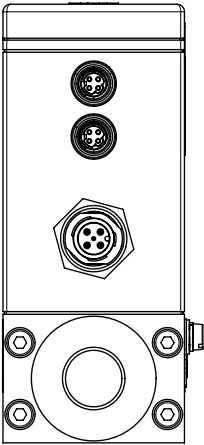

2 x M8 socket, 4-pin (D-coded)	Pin	Assignment
	1	TX +
	2	RX +
	3	TX -
	4	RX -

M12 plug, 5-pin (A-coded)	Pin	Assignment
	1	Shielding
	2	24 V
	3	GND
	4	Not connected
	5	Not connected

### 5.3. Analogue

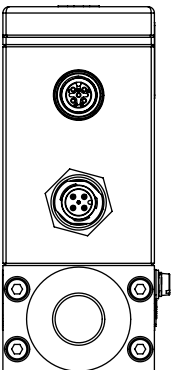

M12 socket, 5-pin (A-coded)	Pin	Assignment
	1	Digital input GND
	2	Digital input +
	3	Relay, reference contact
	4	Relay, normally closed contact
	5	Relay, normally open contact

M12 plug, 5-pin (A-coded)	Pin	Assignment
	1	GND for the analogue output (for MFM) or GND for the analogue output and the set-point value input (for MFC)
	2	24 V
	3	GND for supply voltage
	4	Set-point value input (not connected for MFM)
	5	Analogue output for the measured value

DTS 1000241027 EN Version: X Status: RL (released | freigegeben | validé) printed: 29.04.2024

5.4. PROFIBUS DPV1

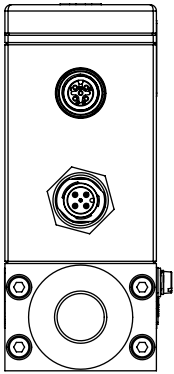

M12 socket, 5-pin (B-coded)	Pin	Assignment
	1	5 V
	2	RxD / TxD (Line A)
	3	DGND
	4	RxD / TxD (Line B)
	5	Not connected

M12 plug, 5-pin (A-coded)	Pin	Assignment
	1	Shielding
	2	24 V
	3	GND
	4	Not connected
	5	Not connected

## 6. Performance specifications

### 6.1. MFM pressure loss diagram

The diagram shows an example of the pressure loss characteristics when air flows through. To determine the pressure loss of other gases, the corresponding air equivalent must first be calculated and the base block used for the other gas taken into account.

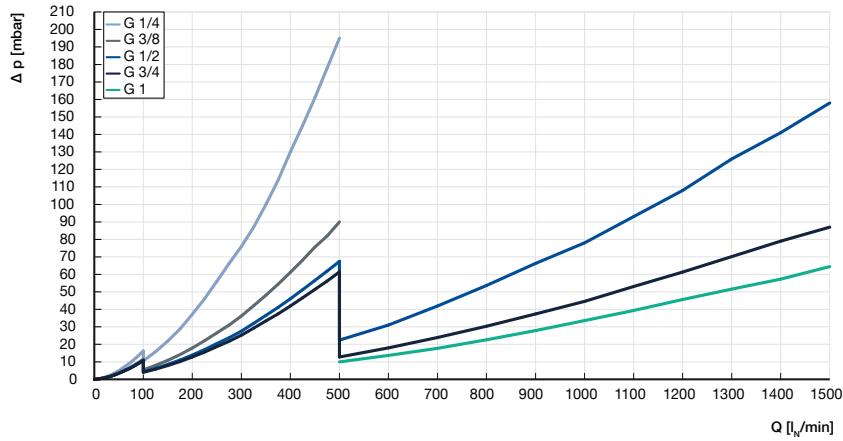

### 6.2. Nominal flow range of typical gases

**Note:**

- All values refer to 1013.25 mbar abs and 273.15 K (0 °C) (Index N)
- Other gases and gas mixtures are possible on request.

Gas	Min. Q <sub>N</sub>	Max. Q <sub>N</sub>
	[l/min]	[l/min]
Acetylene	20	320 (from 65 l/min with air calibration)
Ammonia	8	1000
Argon	20	1600
Carbon dioxide	20	800
Air	20	2500
Methane	20	1200
Propane	20	200
Oxygen	20	2500
Nitrogen	20	2500



### 6.3. Derating diagram for electromotive variants

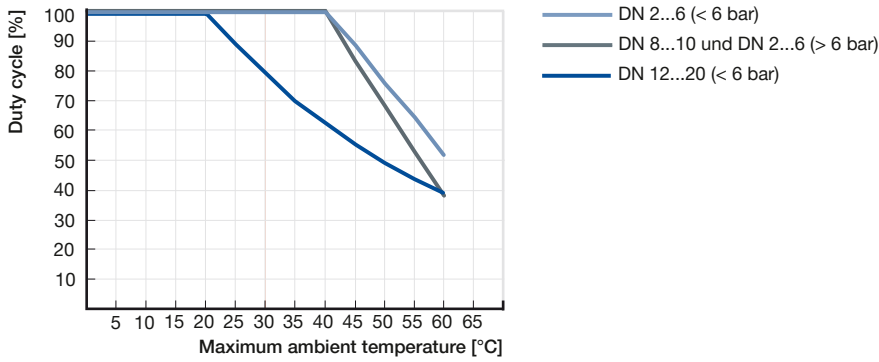

## 7. Product operation

### 7.1. Measuring principle

This sensor works as a hot-film anemometer in the so called CTA operational mode (Constant Temperature Anemometer). 2 resistors with precisely specified temperature coefficients are located directly in the media flow. 3 resistors are located outside the flow. All resistors are connected to form a bridge. The first resistor in the gas flow ( $R_T$ ) measures the fluid temperature, while the second, low value resistor ( $R_S$ ) is heated so that it is maintained at a fixed, predefined overtemperature with respect to the fluid temperature. The heating current required to maintain this temperature is a measure of the heat being removed by the flowing gas and represents the primary measurement. An adequate flow conditioning within the MFC and the calibration with high quality flow standards ensure that the mass of gas flowing per time unit can be derived from the primary signal with high accuracy.

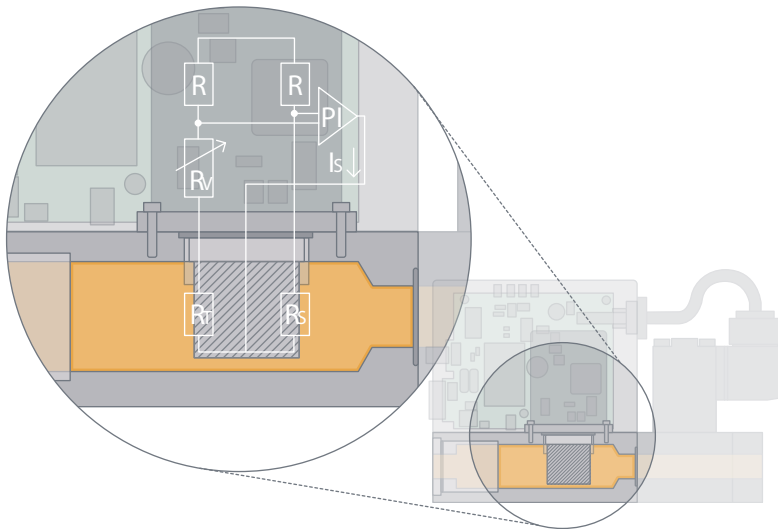

## 8. Product design and assembly

### 8.1. Measures to comply with ATEX requirements

**Note:**

Devices with ATEX conformity meet protection class IP65.

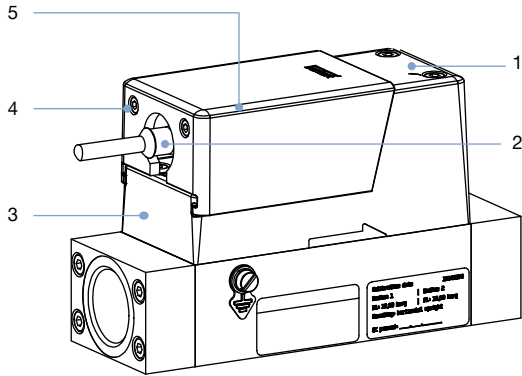

No.	Description
1	The standard requirements for cable glands are fulfilled for variants with external valve.
2	The M12 plug provides protection class IP65 regardless if plugged in or not.
3	The die-cast housing provides IP protection even under high mechanical stress.
4	The screws prevent loosening of the protection cap and hence the M12 connection under tensile stress.
5	The protection cap prevents damage of the M12 plug and all connected elements if mechanical stress is applied. No particular ATEX sockets are required.

## 9. Product accessories

### 9.1. Bürkert Communicator software

#### Note:

The corresponding communication software can be downloaded from the website [Type 8920](#) ▶.

The Bürkert Communicator is the most important software component of the EDIP (Efficient Device Integration Platform). Various features of this universal tool simplify the configuration and parametrisation of devices equipped with a digital CANopen-based interface. With this tool, the user has a complete overview of cyclic process values as well as acyclic diagnostic data. The integrated graphical programming environment enables the creation of decentralised sub-system control functions. The connection to the PC is established with a USB bÜS interface set. The adapter is available as an accessory (see [“10.5. Ordering chart accessories” on page 37](#)).

The Bürkert Communicator enables:

- Configuration, parametrisation and diagnosis of EDIP devices / networks
- Switching between defined gases
- Easy and comfortable mapping of cyclic values
- Graphic display, monitoring and storage of process values
- Firmware update of the connected EDIP devices
- Saving and restoring device configurations
- Zero-point adjustment in case of changed ambient conditions
- Guided re-calibration routine

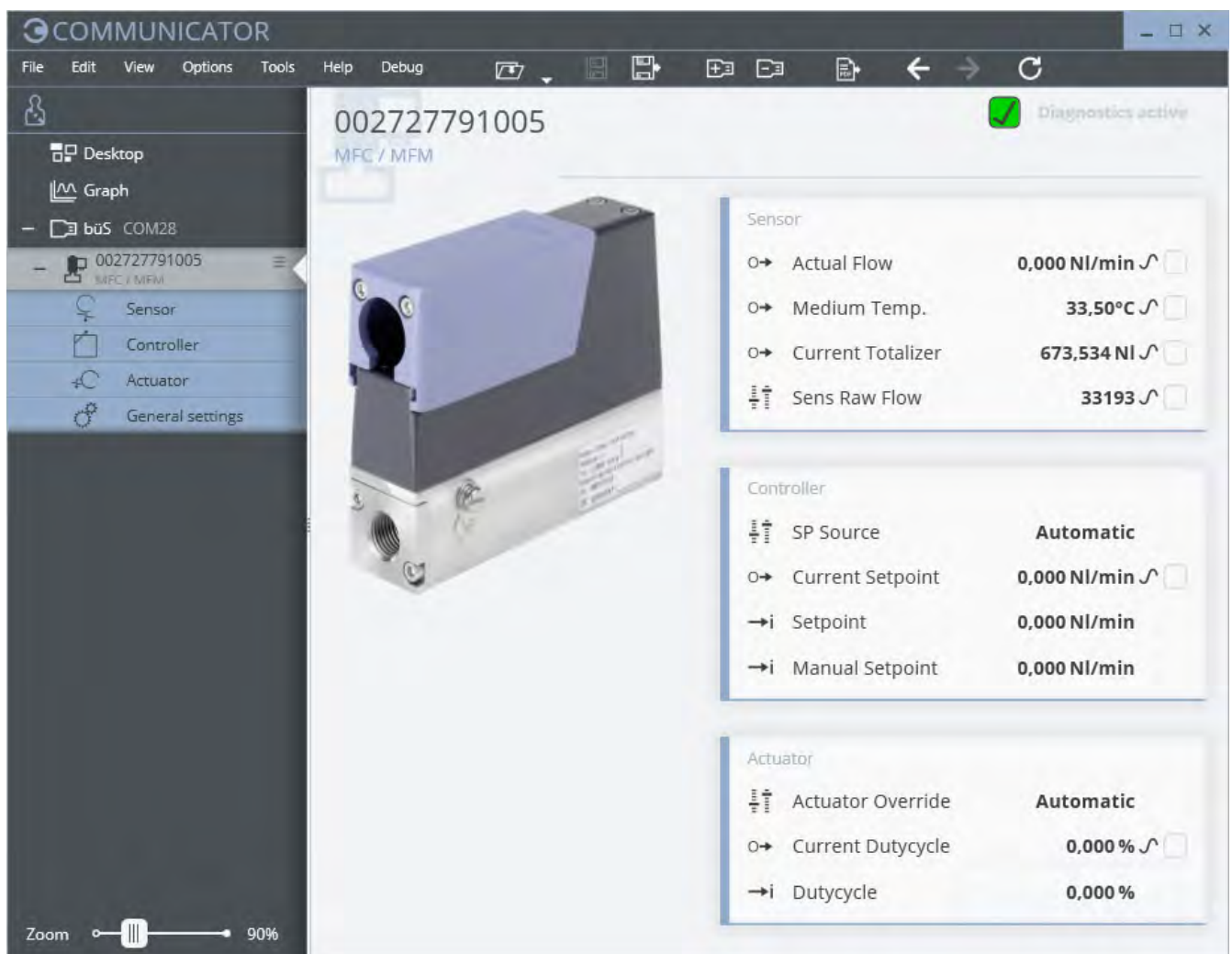

## 9.2. Connecting Type 8746 with the Bürkert Communicator software

The Bürkert Communicator interface is based on CANopen. The appropriate bus termination is mandatory. For Type 8746 Analogue, Industrial Ethernet or PROFIBUS DPV1, activate the termination resistor switch on the bus stick. For Type 8746 bus/CANopen, the termination resistor must not be activated in case the device is already integrated in a properly terminated bus network.

- For Type 8746 Analogue, Industrial Ethernet or PROFIBUS DPV1, the connection is established via the micro USB socket on the device (USB bus interface set 2 contains the necessary accessories).
- For Type 8746 bus/CANopen, the connection is established via the 5-pin M12 plug (USB bus interface set 1 contains the necessary accessories).

Please note: no external power supply must be connected to the micro USB socket. The device must be provided with power as described in chapter “5. Device/Process connections” on page 30.

## 9.3. Configuration management for easy device replacement

Depending on the electrical connection of the MFC, the following options for device replacement are available:

- If a device needs to be replaced, the memory card can be removed from the defective device and inserted into the new one. This transfers all data of the device to be replaced to the new device. The memory card is available as an accessory and must be ordered separately (see “10.5. Ordering chart accessories” on page 37).
- Option for Type 8746 bus/CANopen: The device is exchanged via the configuration provider of the higher-level gateway control (ME43 or ME63). In the gateway, a memory card is required. The memory card is available as an accessory and must be ordered separately (see “10.5. Ordering chart accessories” on page 37).

In order to successfully exchange the device, it is necessary that both the new device and the device to be replaced possess the same device ID.

## 9.4. Web server for Industrial Ethernet variant

The Industrial Ethernet-based devices (except for the EtherCAT® protocol) from software version A.13.00.00 or higher dispose of an integrated web server. The server can be accessed via a web browser by entering the device’s IP address (factory setting IP192.168.1.100).

# 10. Ordering information

## 10.1. Bürkert eShop



### Bürkert eShop – Easy ordering and quick delivery

You want to find your desired Bürkert product or spare part quickly and order directly? Our online shop is available for you 24/7. Sign up and enjoy all the benefits.

[Order online now](#)

## 10.2. Recommendation regarding product selection

### Note:

Use the Product Enquiry Form (see “10.4. Bürkert Product Enquiry Form” on page 37) for the device details and send it to us once completed.

For the proper choice of the actuator orifice within the MFC, you need to know not only the required maximum flow rate  $Q_N$  but also the pressure values directly before and after the MFC ( $p_1$ ,  $p_2$ ) at  $Q_N$ . In general, these pressures are not the same as the overall inlet and outlet pressures of the whole plant, because usually, additional flow resistors (tubing, additional shut-off valves, nozzles etc.) are present both before and after the MFC.

Please use the Product Enquiry Form to indicate the pressures directly before and after the MFC. If these are unknown or not accessible to measurement, estimates are to be made by taking into account the approximate pressure drops over the flow resistors before and after the MFC, at  $Q_N$  flow rate. In addition, please quote the maximum inlet pressure  $p_{1,max}$  to be encountered. This data is needed to make sure the actuator is able to provide a close-tight function within all the specified modes of operation.

### 10.3. Bürkert product filter



#### Bürkert product filter – Get quickly to the right product

You want to select products comfortably based on your technical requirements? Use the Bürkert product filter and find suitable articles for your application quickly and easily.

[Try out our product filter](#)

### 10.4. Bürkert Product Enquiry Form

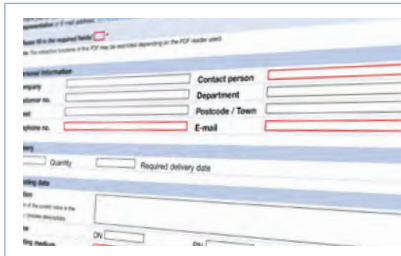

#### Bürkert Product Enquiry Form – Your enquiry quickly and compactly













Would you like to make a specific product enquiry based on your technical requirements? Use our Product Enquiry Form for this purpose. There you will find all the relevant information for your Bürkert contact. This will enable us to provide you with the best possible advice.

[Fill out the form now](#)

### 10.5. Ordering chart accessories

Description	Article no.
<b>General accessories</b>	
USB büS interface set 1 (Type 8923) for connection to the Bürkert Communicator software: includes connection cable (M12 and micro USB), stick with integrated terminating resistor, power supply and software	772426
USB büS interface set 2 (Type 8923) for connection to the Bürkert Communicator software: including büS stick, connection cable to M12 plug, M12 connection cable on micro USB for the büS service interface and Y-distributor, cable length: 0.7 m	772551
Power supply unit Phoenix Class2 (Type 1573), 85...240 V AC/24 V DC, 1.25 A, NEC Class 2 (UL 1310)	772438
Power supply unit for standard rail (Type 1573), 100...240 V AC/24 V DC, 1 A, NEC Class 2 (UL 1310)	772361
Power supply unit for standard rail (Type 1573), 100...240 V AC/24 V DC, 2 A, NEC Class 2 (UL 1310)	772362
Power supply unit for standard rail (Type 1573), 100...240 V AC/24 V DC, 4 A	772363
Memory card	On request
Device description files for software interfaces	Download from <b>Type 8746</b>
Software Bürkert Communicator	Download from <b>Type 8920</b>
<b>For Type 8746 büS/CANopen</b>	
büS cable extension, M12, cable length: 0.1 m	772492
büS cable extension, M12, cable length: 0.2 m	772402
büS cable extension, M12, cable length: 0.5 m	772403
büS cable extension, M12, cable length: 1 m	772404
büS cable extension, M12, cable length: 1 m	772405
büS socket, M12, straight, A-coded <sup>1.)</sup>	772416
büS plug, M12, straight, A-coded <sup>1.)</sup>	772417
büS socket, M12, angled, A-coded <sup>1.)</sup>	772418
büS plug, M12, angled, A-coded <sup>1.)</sup>	772419
büS Y plug	772420
büS Y plug for linking two separately supplied segments of a büS network	772421
büS plug, M12, terminating resistor 120 Ω	772424
büS plug, M12, terminating resistor 120 Ω	772425
LabVIEW device driver	On request

DTS 1000241027 EN Version: X Status: RL (released | freigegeben | valide) printed: 29.04.2024

Description	Article no.
EDS file	Download from <b>Type 8746 ▶</b>
<b>For Type 8746 Industrial Ethernet</b>	
M8 plug, D-coded, to M12 plug, D-coded, cable length: 0.3 m	575443 
<b>For Type 8746 Analogue</b>	
M12 plug with cable, on strand, A-coded, cable length: 5 m	566923 
M12 plug with cable, on strand, A-coded, cable length: 10 m	571393 
M12 socket with cable, on strand, A-coded, cable length: 5 m	560365 
M12 socket with cable, on strand, A-coded, cable length: 10 m	563108 
<b>For Type 8746 PROFIBUS DPV1</b>	
M12 socket with cable, on strand, A-coded, cable length: 5 m	560365 
M12 socket with cable, on strand, A-coded, cable length: 10 m	563108 
büS socket, M12, straight, A-coded <sup>1.)</sup>	772416 
M12 plug, 5-pin, B-coded, straight	918198 
M12 socket 5-pin, straight (coupling)	918447 
PROFIBUS DPV1 T distributor	918531 
PROFIBUS DPV1 terminating resistor, M12 plug, B-coded	902553 

1.) For space reasons, M12 individual cable plugs may not be suitable for simultaneous use on the same side as a Y distributor. Use a commercially available covered cable in this case.